



INDUSTRIAL ROTARY SCREW AIR COMPRESSOR

10B Series Open

25, 30, 40 HP Standard & 24KT

PARTS LIST

AIR CARE SEMINAR TRAINING

Sullair Air Care Seminars are 3-day courses that provide hands-on instruction in the proper operation, maintenance and service of Sullair equipment. Individual seminars on Industrial compressors and compressor electrical systems are presented at regular intervals throughout the year at a dedicated training facility at Sullair's corporate headquarters in Michigan City, Indiana.

Instruction includes discussion of the function and installation of Sullair service parts, troubleshooting of the most common problems, and actual equipment operation. The seminars are recommended for maintenance and service personnel.

For detailed course outlines, schedule and cost information contact:

Sullair Corporate Training Department
1-800-348-2722 or 219-879-5451 (ext. 1867)

– Or Write –

Sullair Corporation
3700 E. Michigan Blvd.
Michigan City, IN 46360
Attn: Service Training Department

TABLE OF CONTENTS

Section 1 ILLUSTRATIONS AND PARTS LIST

PAGE	
1	1.1 PROCEDURE FOR ORDERING PARTS
1	1.2 RECOMMENDED SPARE PARTS LIST
2	1.3 MOTOR, COMPRESSOR, FRAME AND PARTS
6	1.4 AIR INLET SYSTEM
8	1.5 COMPRESSOR COOLING AND LUBRICATION SYSTEM – AIR–COOLED (25–40HP)
12	1.6 COMPRESSOR COOLING AND LUBRICATION SYSTEM – WATER–COOLED (25 & 30HP)
14	1.7 COMPRESSOR COOLING AND LUBRICATION SYSTEM – WATER–COOLED (40HP)
16	1.8 COMPRESSOR DISCHARGE SYSTEM
20	1.9 ELECTRICAL BOX
22	1.10 PNEUMATIC CONTROLS
26	1.11 INSTRUMENT PANEL – OPEN AND ENCLOSURE OPTION
28	1.12 AIR–COOLED AFTERCOOLING OPTION (25 AND 30HP)
30	1.13 WATER–COOLED AFTERCOOLING OPTION (25 AND 30HP)
32	1.14 WATER–COOLED AFTERCOOLING OPTION (40HP)
34	1.15 WATER–COOLED AND AIR–COOLED ENCLOSURE AND PARTS OPTION
36	1.16 HEAVY DUTY FILTER OPTION
38	1.17 OPTIONAL AIR TANK – 120 AND 200 GALLON
40	1.18 DECAL GROUP

NOTES

Section 1 ILLUSTRATIONS AND PARTS LIST

1.1 PROCEDURE FOR ORDERING PARTS

Parts should be ordered from the nearest Sullair Representative or the Representative from whom the compressor was purchased. If for any reason parts cannot be obtained in this manner, contact the factory directly at the address or phone numbers listed below.

When ordering parts always indicate the **Serial Number** of the compressor. This can be obtained from the Bill of Lading for the compressor or from the Serial Number Plate located on the compressor.

SULLAIR CORPORATION
 Subsidiary of Sundstrand Corporation
 3700 East Michigan Boulevard
 Michigan City, Indiana 46360

Telephone: (219) 879-5451
 See Toll-free Number Below
 FAX: (219) 874-1273

SULLAIR CORPORATION
 Parts Distribution Division and Service Department
 1625 E. Second Street
 Michigan City, Indiana 46360

Telephone: 1-800-348-2722 or
 (219) 879-5451
 FAX: (219) 874-1835 (Parts)
 FAX: (219) 874-1805 (Service)

1.2 RECOMMENDED SPARE PARTS LIST

DESCRIPTION	KIT NUMBER	QUANTITY
element for main fluid filter 250025-521	250025-525 (std. & 24KT)	2
repair kit for separator element 250034-111	250034-112 (std.)	1
	250034-114 (24KT)	1
repair kit for separator element 250034-113	250034-114 (std. & 24KT)	1
replacement element for air filter 410036	042445 (std. & 24KT)	1
repair kit for pressure regulator 250017-280	250019-453 (std. & 24KT)	1
repair kit for solenoid valve 250017-993	250018-970 (std. & 24KT)	1
replacement coil for solenoid valve 250017-993	250018-971 (std. & 24KT)	1
replacement gasket for flexible coupling 040033	040517 (std.)	1
replacement gasket for flexible coupling 250007-544	250007-559 (24KT)	1
repair kit for return line strainer 241771	241772 (std. & 24KT)	1
repair kit for thermal valve 250025-620	250025-621 (std. & 24KT)	1
repair kit for air inlet valve 250025-654	250019-451 (std. & 24KT)	1
seal kit for minimum pressure valve 241581	250026-758 (std. & 24KT)	1
repair kit for blowdown valve 250025-655	250031-772 (std. & 24KT)	1
repair kit for shaft seal	001836-007 (std. & 24KT)	1
repair kit for separator/trap 040847	044374 (std. & 24KT)	1
replacement spring for check valve 049905	250003-657	1
SRF 1/4000 fluid (5 gallons)	250019-662 (std.)	1
24KT fluid (5 gallons)	046850-001 (24KT)	1
Sullube 32 fluid (5 gallons)	250022-669	1

PLEASE NOTE: WHEN ORDERING PARTS, INDICATE SERIAL NUMBER OF COMPRESSOR

Section 1 ILLUSTRATIONS AND PARTS LIST

1.3 MOTOR, COMPRESSOR, FRAME AND PARTS

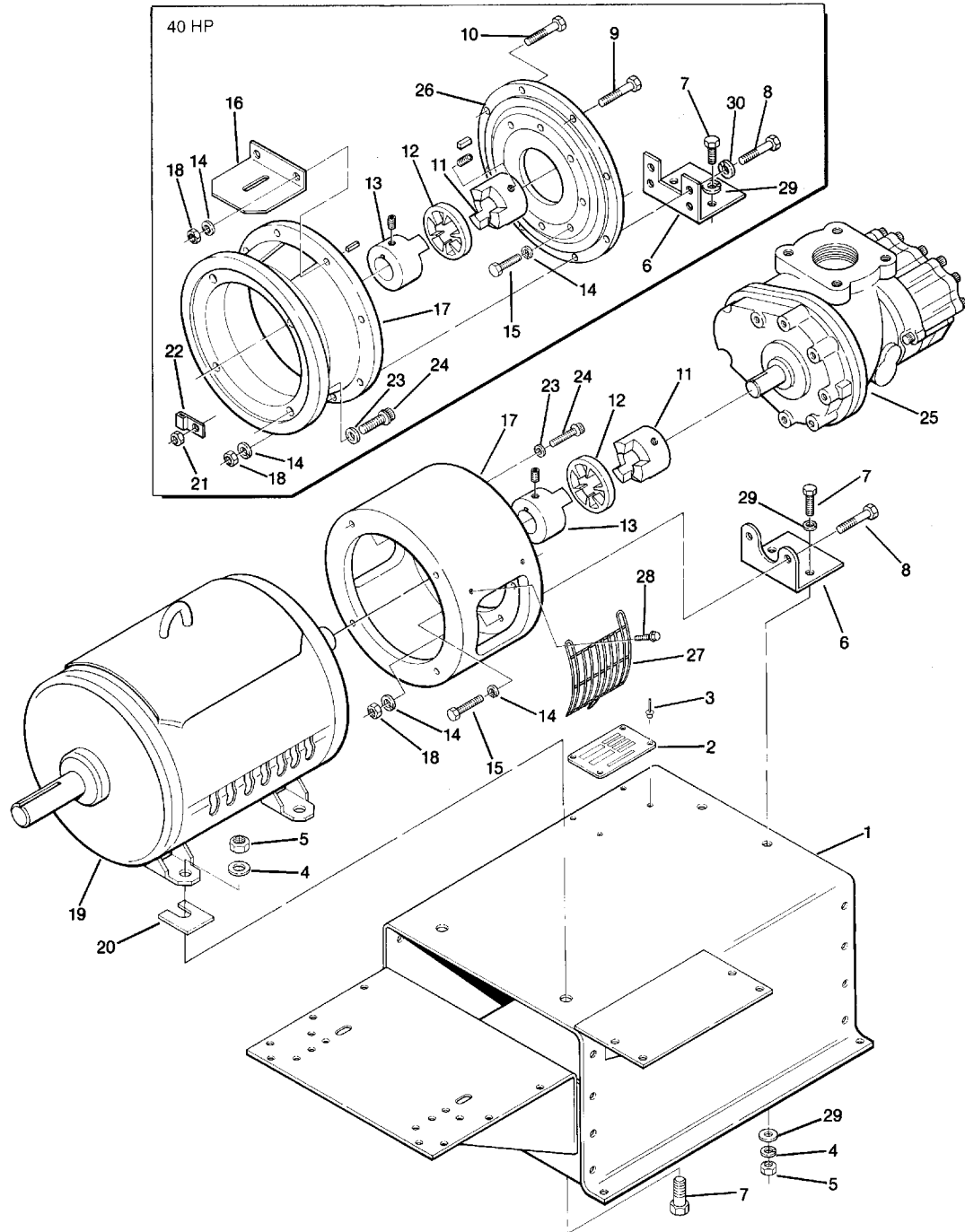

Section 1 ILLUSTRATIONS AND PARTS LIST

1.3 MOTOR, COMPRESSOR, FRAME AND PARTS

<i>key number</i>	<i>description</i>	<i>standard part number</i>	<i>24KT part number</i>	<i>quantity</i>
1	base, motor/compressor	013569	013569	1
2	nameplate, serial number	040052	040052	1
3	rivet, pop 1/8" x 1/2"	843102-050	843102-050	4
4	washer, springlock – regulating 1/2"	837508-125	837508-125	4
5	nut, hex 1/2" – 13	824208-448	824208-448	4
6	angle, compressor mounting (25,30HP)	250038-863	250038-863	1
	•angle, compressor mounting (40HP)	250004-580	250004-580	1
7	capscrew, hex head gr5 1/2" x 1 1/2"	828608-150	828608-150	2
8	capscrew, hex head gr5 3/8" x 1 1/4"	828606-125	828606-125	7
	•capscrew, hex head gr5 3/8" x 1 3/4"	828606-175	828606-175	1
9	capscrew, hex head gr5 3/8" x 2 1/2"	828606-250	828606-250	2
10	capscrew, hex head gr5 5/16" x 1 3/4"	828605-175	828605-175	1
11	coupling, hub (25, 30HP)	045673	045673	1
	• coupling, hub (40HP)	250004-639	250004-639	1
12	element, drive coupling (25, 30HP)	045672	045672	1
	• element, drive coupling (40HP)	250004-638	250004-638	1
13	hub, motor (25, 30HP)	045671	045671	1
	• hub, motor (40HP)	250004-640	250004-640	1
14	washer, springlock – regulating 3/8"	837506-094	837506-094	15
15	capscrew, hex head gr5 3/8" x 1 1/4"	828606-125	828606-125	7
16	plate, motor/compressor (40HP)	225980	225980	1
17	adapter, motor (25, 30HP)	250038-448	250038-448	1
	•adapter, motor (40HP)	231977	231977	1
18	nut, hex 3/8" – 16	824206-337	824206-337	6
19	motor, 25HP	250029-985	250029-985	1
	• motor, 30HP	250029-986	250029-986	1
	• motor, 40HP	250029-987	250029-987	1
20	shim set, motor	020293	020293	1
21	nut, hex plated 5/16" x 18"	825305-283	825305-283	1
22	lug, Scrulug	849215-025	849215-025	1
23	washer, springlock 1/2" (25,30HP)	837508-125	837508-125	1
	•washer, springlock regular 5/8"	837510-156	837510-156	4
24	capscrew, ferry head 1/2" – 13 x 1 1/4" (25,30HP)	828408-125	828408-125	4
	•capscrew, ferry head 5/8" x 1 1/2" (40HP)	828410-150	828410-150	4

(Continued on Page 5)

PLEASE NOTE: WHEN ORDERING PARTS, INDICATE SERIAL NUMBER OF COMPRESSOR

Section 1 ILLUSTRATIONS AND PARTS LIST

1.3 MOTOR, COMPRESSOR, FRAME AND PARTS

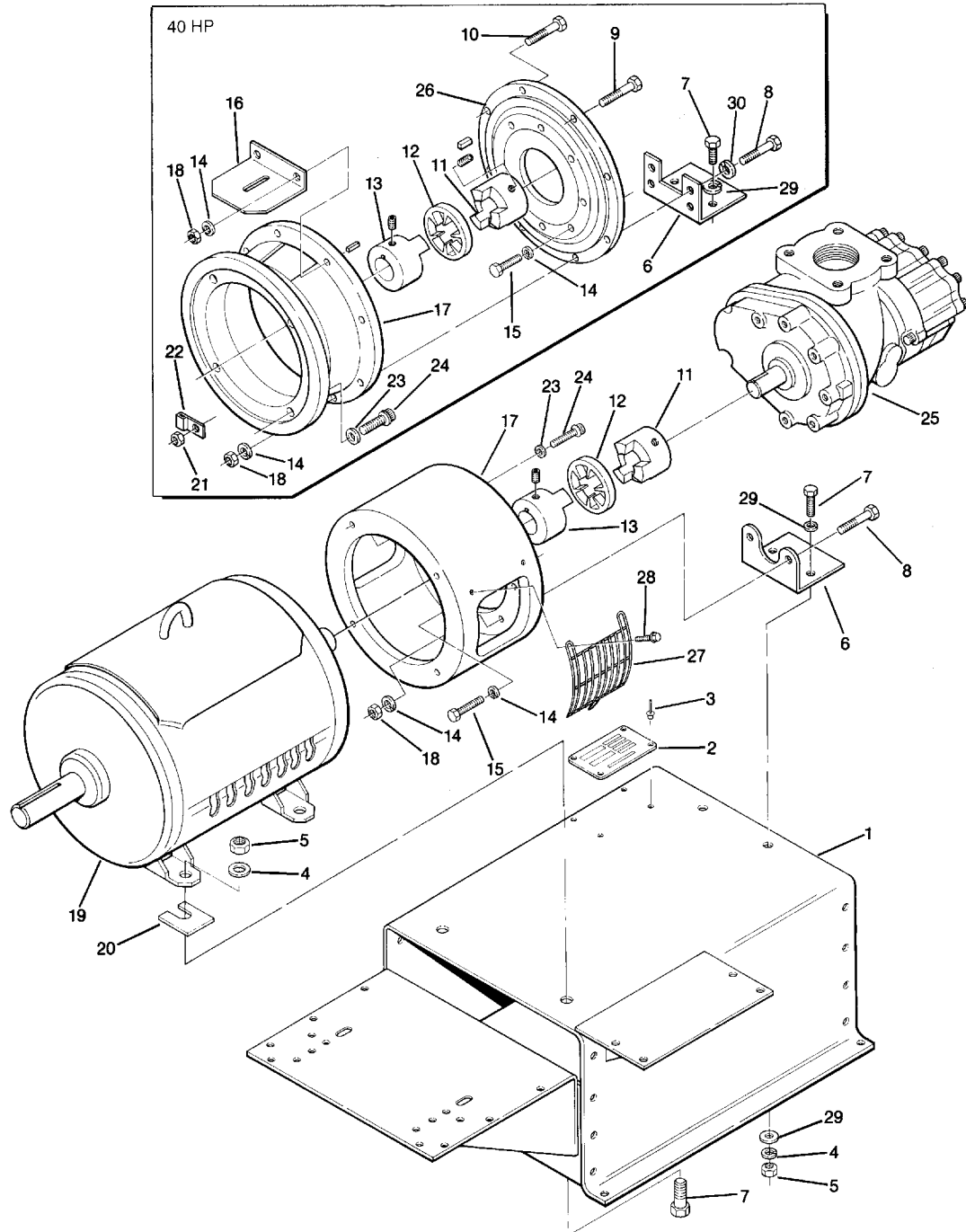

Section 1

ILLUSTRATIONS AND PARTS LIST

1.3 MOTOR, COMPRESSOR, FRAME AND PARTS (Continued)

<i>key number</i>	<i>description</i>	<i>standard part number</i>	<i>24KT part number</i>	<i>quantity</i>
25	compressor unit, 10B Series(I)	—	—	1
26	adapter, SAE 5	250009-542	250009-542	1
27	grille, coupling guard (25,30HP)	250038-863	250038-863	2
28	screw, ser washer $\frac{5}{16}$ " x $\frac{3}{4}$ " (25,30HP)	829705-075	829705-075	6
29	washer, $\frac{1}{2}$ "	837208-112	837208-112	2
30	washer, $\frac{3}{8}$ "	838206-071	838206-071	1

(I) There is an exchange program whereby a remanufactured compressor unit can be obtained from Sullair distributors or the factory at less cost than the owner could repair the unit. For information regarding the unit exchange program, contact your nearest Sullair representative or the Sullair Corporation.

The shaft seal is not considered part of the compressor unit in regard to the 2 year warranty. The normal Sullair parts warranty applies. For shaft seal repairs, order shaft seal repair kit no. 001836-007.

PLEASE NOTE: WHEN ORDERING PARTS, INDICATE SERIAL NUMBER OF COMPRESSOR

Section 1
ILLUSTRATIONS AND PARTS LIST

1.4 AIR INLET SYSTEM

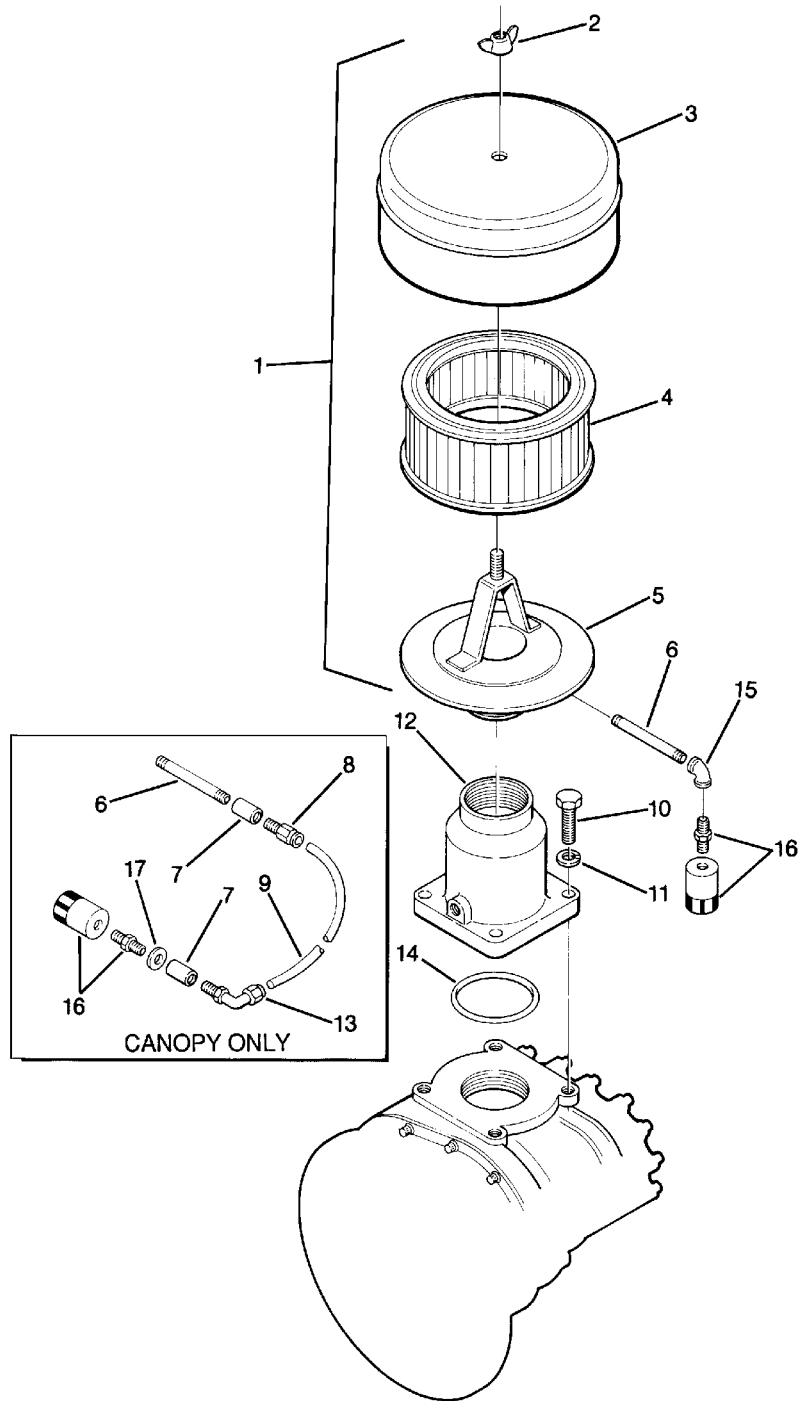

Section 1 ILLUSTRATIONS AND PARTS LIST

1.4 AIR INLET SYSTEM

<i>key number</i>	<i>description</i>	<i>standard part number</i>	<i>24KT part number</i>	<i>quantity</i>
1	air filter assembly (I) (includes Items 2, 3, 4, 5)	410036	410036	1
2	nut, wing ¼"–20	824815–004	824815–004	1
3	hood, air filter	043392	043392	1
4	element, air filter	042445	042445	1
5	base, filter	017966	017966	1
6	nipple, pipe ⅛" x 3"	823102–030	823102–030	1
7	coupling, pipe galvanized ⅛"	803215–005	803215–005	2
8	connector, tube start ⅛"mnpt x ¼"t	813604–125	813604–125	1
9	tubing, plastic ¼"od	250024–745	250024–745	2½ ft
10	capscrew, hex gr5 ⅝"–11 x 1¼"	828610–125	828610–125	4
11	washer, springlock ⅝"	837510–156	837510–156	4
12	valve, air inlet 2½" (II)	250025–654	250025–654	1
13	connector, tube–el ⅛"mpt x ¼"t	813704–125	813704–125	1
14	o–ring, 3½" x ⅛"	826502–238	826502–238	1
15	elbow, pipe galvanized ⅛"	801515–005	801515–005	1
16	indicator, air filter maintenance	045757	045757	1
17	washer, flat ⅜"	838206–071	838206–071	1

(I) For maintenance on air filter assembly no. 410036, order replacement element no. 042445.

(II) For maintenance on air inlet valve no. 250025–654, order repair kit no. 250019–451.

PLEASE NOTE: WHEN ORDERING PARTS, INDICATE SERIAL NUMBER OF COMPRESSOR

Section 1 ILLUSTRATIONS AND PARTS LIST

1.5 COMPRESSOR COOLING AND LUBRICATION SYSTEM – AIR-COOLED (25–40HP)

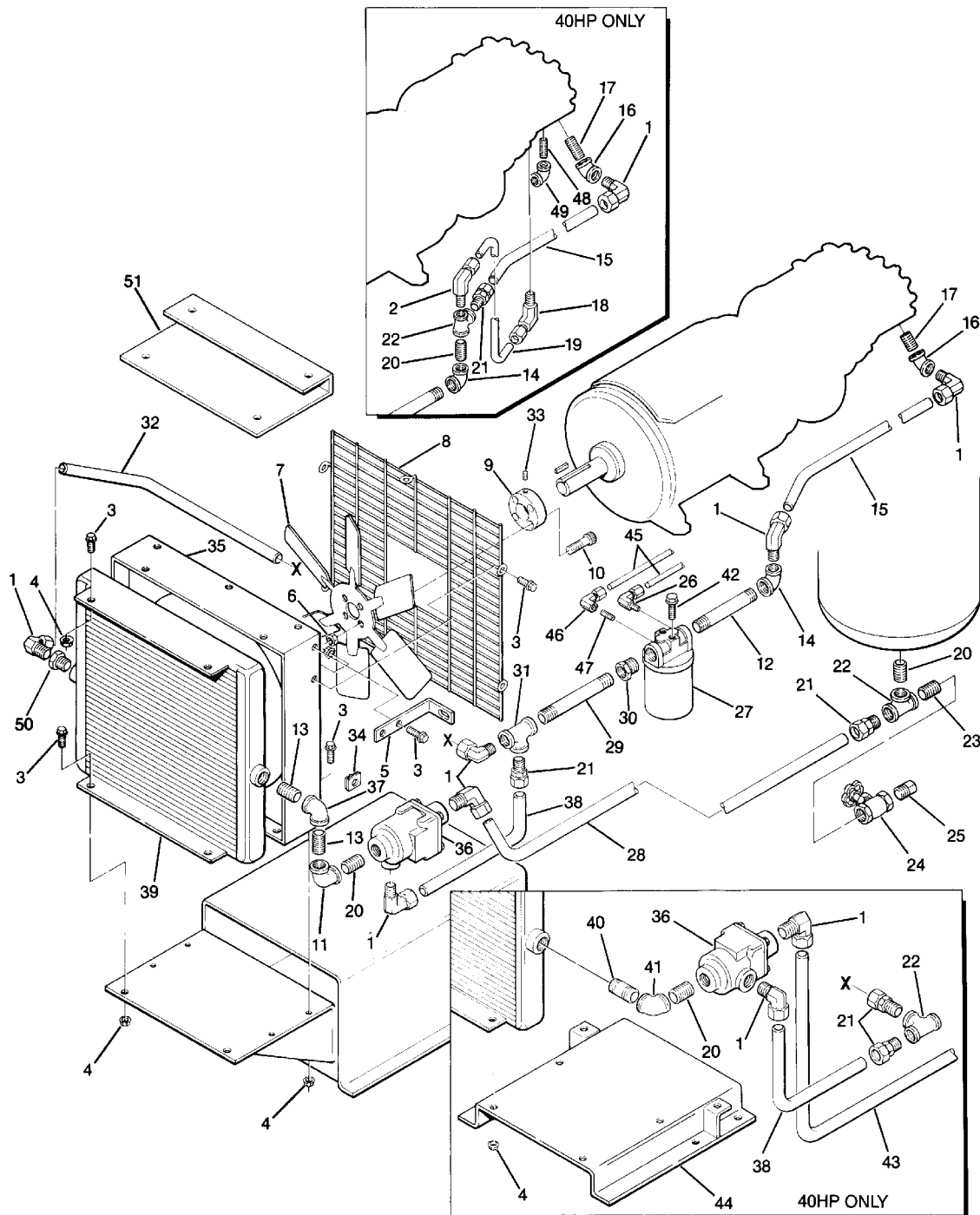

Section 1 ILLUSTRATIONS AND PARTS LIST

1.5 COMPRESSOR COOLING AND LUBRICATION SYSTEM – AIR–COOLED (25–40HP)

<i>key number</i>	<i>description</i>	<i>standard part number</i>	<i>24KT part number</i>	<i>quantity</i>
1	elbow, 90° 3/4" x 3/4" (25, 30HP)	810512–075	810512–075	6
	• elbow, 90° 3/4" x 3/4" (40HP)	810512–075	810512–075	5
2	elbow, tube–m 3/8" x 1/2" (40HP)	810506–050	810506–050	1
3	screw, hex head ser washer 5/16" x 3/4" (25, 30HP)	829705–075	829705–075	12
	•screw, hex head ser washer 5/16" x 3/4" (40HP)	829705–075	829705–075	18
4	nut, hex ser washer plated 5/16"–18 (25, 30HP)	825305–283	825305–283	7
	•nut, hex ser washer plated 5/16"–18 (40HP)	825305–283	825305–283	13
5	brace, cooler/starter	250018–605	250018–605	1
6	nut, hex locking plated 5/16"–18 (25, 30HP)	825505–166	825505–166	4
	•nut, locking 3/8"–16 (40HP)	825506–198	825506–198	4
7	fan, cooling (25, 30HP)	042492	042492	1
	• fan, cooling (40HP)	249012	249012	1
8	guard, fan	225962	225962	1
9	hub, fan (25, 30HP)	023350	023350	1
	• hub, fan (40HP)	231981	231981	1
10	capscrew, ferry 5/16" x 1 1/2" (25, 30HP)	828405–150	828405–150	4
	• capscrew, ferry 3/8" x 1 3/4" (40HP)	828406–175	828406–175	4
11	elbow, 90° reducing 1" x 3/4" (25, 30HP)	801604–030	801604–030	1
12	nipple, pipe 1 1/4" x 6"	822120–060	822120–060	1
13	nipple, close 1" (25, 30HP)	822216–000	822216–000	2
14	elbow, 90° reducing 1 1/4 x 3/4"	801605–030	801605–030	1
15	tube, fluid stop	232823	232823	1
16	elbow, 45° pipe 3/4"	801415–030	801415–030	1
17	nipple, pipe 3/4" x 2 1/2"	822112–025	822112–025	1
18	elbow, tube–m 3/8" x 3/8" (40HP)	810506–038	810506–038	1
19	tubing, copper 3/8" (40HP)	840115–006	840115–006	2 ft.
20	nipple, close 3/4" (25, 30HP)	822212–000	822212–000	2
	• nipple, close 3/4" (40HP)	822212–000	822212–000	3
21	connector, tube 3/4" x 3/4" (25, 30HP)	810212–075	810212–075	2
	•connector, tube 3/4" x 3/4" (40HP)	810212–075	810212–075	4
22	tee, reducing 3/4" x 1/2" x 3/4" (25, 30HP)	802203–023	802203–023	1
	•tee, reducing 3/4" x 1/2" x 3/4" (40HP)	802203–023	802203–023	2
23	nipple, close 1/2"	822208–000	822208–000	1

(continued on page 11)

PLEASE NOTE: WHEN ORDERING PARTS, INDICATE SERIAL NUMBER OF COMPRESSOR

Section 1 ILLUSTRATIONS AND PARTS LIST

1.5 COMPRESSOR COOLING AND LUBRICATION SYSTEM – AIR-COOLED (25–40HP)

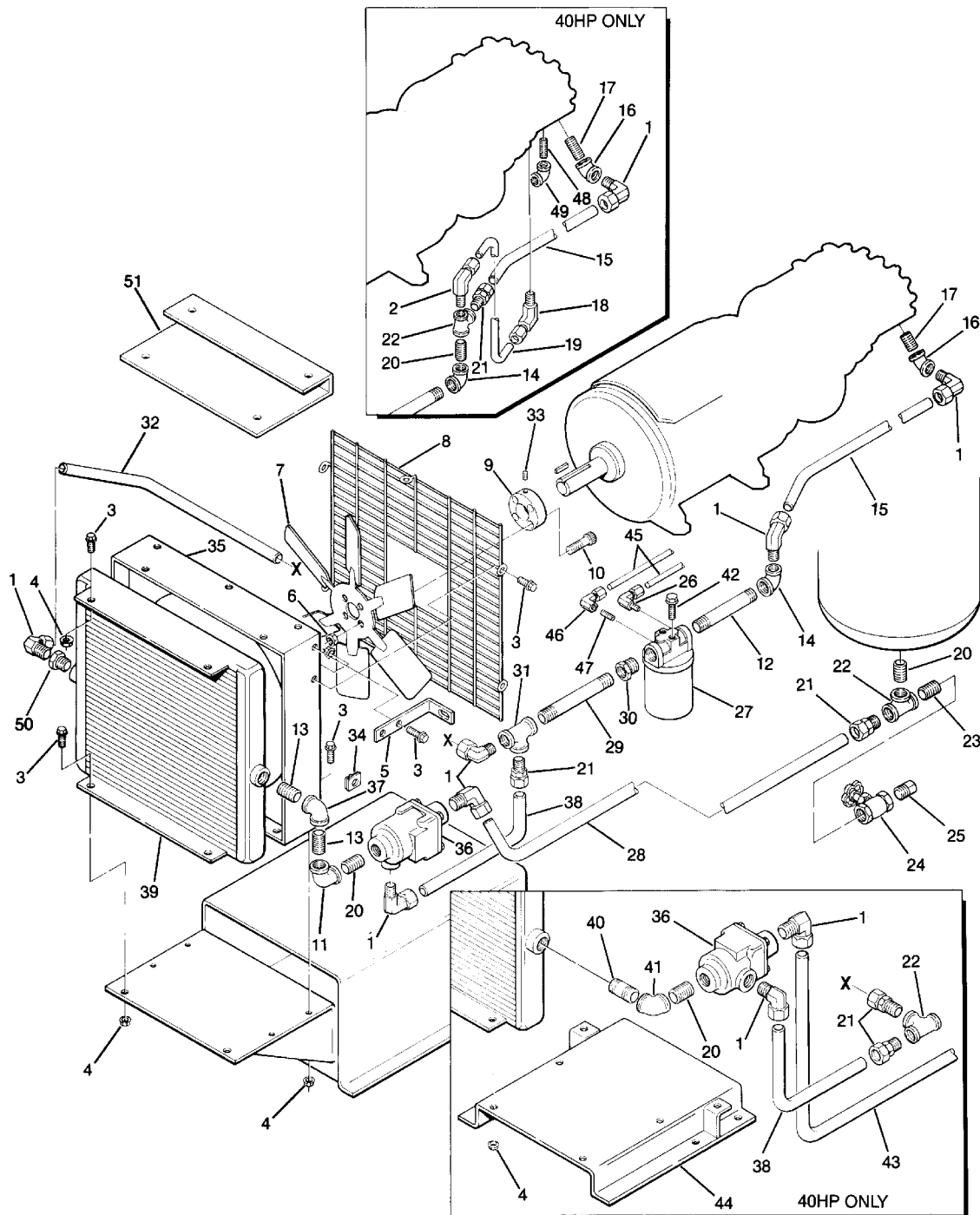

Section 1 ILLUSTRATIONS AND PARTS LIST

1.5 COMPRESSOR COOLING AND LUBRICATION SYSTEM – AIR–COOLED (25–40HP) (Cont'd.)

<i>key number</i>	<i>description</i>	<i>standard part number</i>	<i>24KT part number</i>	<i>quantity</i>
24	valve, globe ½"	041007	041007	1
25	plug, pipe ½"	807800–020	807800–020	1
26	elbow, 90° tube ¼" x ⅛"	810504–012	810504–012	1
27	filter, fluid (I)	250025–521	250025–521	1
28	tube, cooler fluid cooler to sump (25, 30HP)	232942	232942	1
	•tube, cooler fluid cooler to sump (40HP)	221706	221706	1
29	nipple, pipe ¾" x 9" (25, 30HP)	822112–090	822112–090	1
	• nipple, pipe ¾" x 13½" (40HP)	822112–135	822112–135	1
30	bushing, hex 1¼" x ¾"	802105–030	802105–030	1
31	tee, pipe ¾"	802415–030	802415–030	1
32	tube, filter to cooler (25, 30HP)	232940	232940	1
	• tube, filter to cooler (40HP)	221704	221704	1
33	screw, hex set ⅝" x ½"	250010–322	250010–322	2
34	clip, retainer	861505–140	861505–140	5
35	shroud, fan (25, 30HP)	011994	011994	1
	• shroud, fan (40HP)	013315	013315	1
36	valve, thermal (II)	250025–620	250025–620	1
37	elbow, 90° pipe 1"	801515–040	801515–040	1
38	tube, thermal valve to filter	232939	232939	1
39	cooler, fluid (25, 30HP)	241852	241852	1
	• cooler, fluid (40HP)	044531	044531	1
40	nipple, pipe ¾" x 2" (40HP)	822112–020	822112–020	1
41	elbow, 90° pipe ¾" (40HP)	801515–030	801515–030	1
42	screw, hex serrated washer ⅝" x ½"	829705–050	829705–050	2
43	tube, cooler, sump (40HP)	221706	221706	1
44	support, cooler (40HP)	014690	014690	1
45	tubing, steel ¼"	841015–004	841015–004	10 ft.
46	elbow, tube–f ¼" x ⅛"	810404–012	810404–012	1
47	nipple, pipe galvanized ⅛" x 1½"	823102–015	823102–015	1
48	nipple, ¼" x close	823204–000	823204–000	1
49	elbow, reducing ⅜" x ¼"	801601–015	801601–015	1
50	bushing, reducing 1" x ¾"	802104–030	802104–030	1
51	plate, adapter	224076	224076	1

(I) For maintenance on fluid filter no. 250025–521, order repair kit no. 250025–525.

(II) For maintenance on thermal valve no. 250025–620, order repair kit no. 250025–621.

PLEASE NOTE: WHEN ORDERING PARTS, INDICATE SERIAL NUMBER OF COMPRESSOR

Section 1
ILLUSTRATIONS AND PARTS LIST

1.6 COMPRESSOR COOLING AND LUBRICATION SYSTEM – WATER-COOLED (25 AND 30HP)

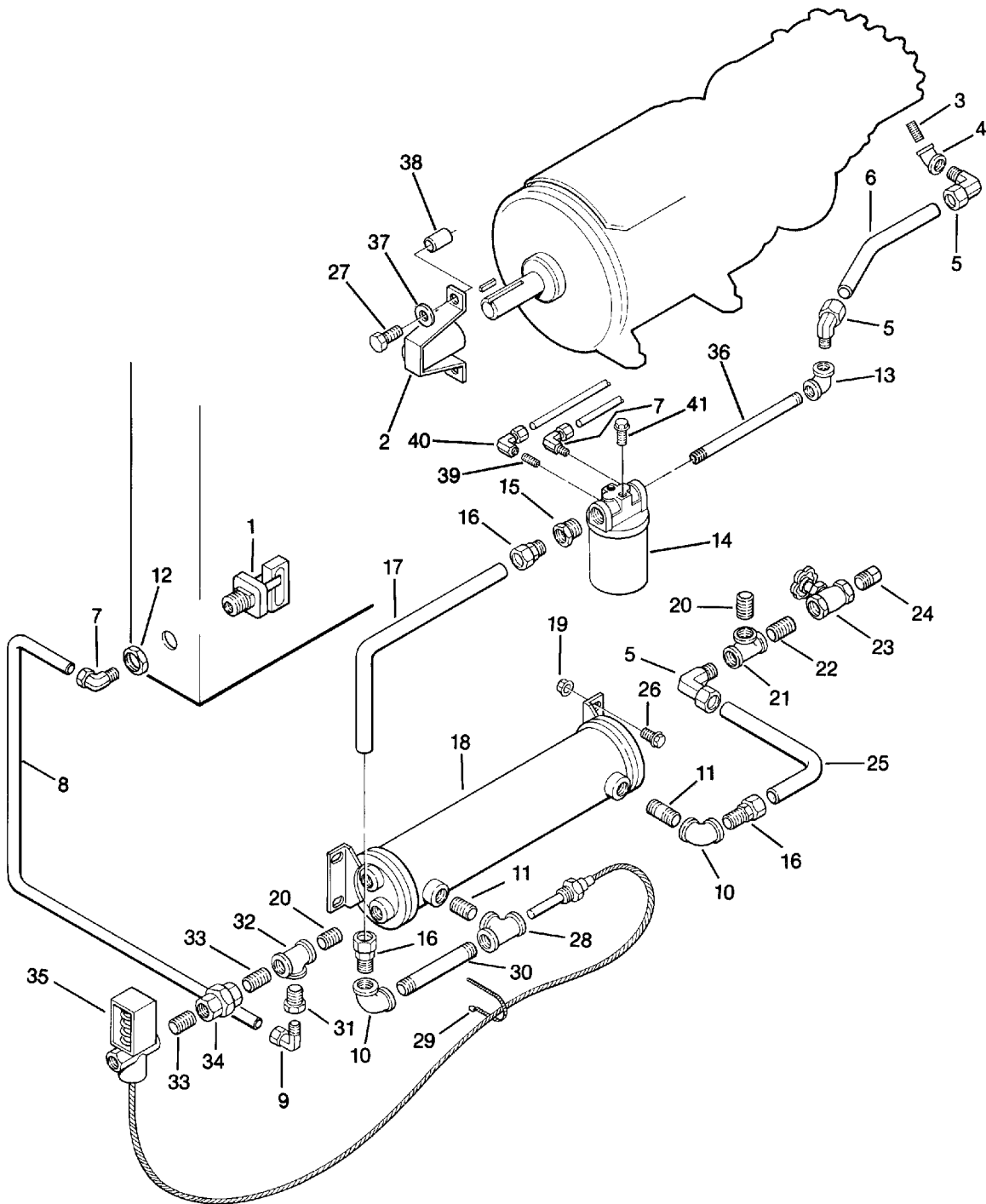

Section 1 ILLUSTRATIONS AND PARTS LIST

1.6 COMPRESSOR COOLING AND LUBRICATION SYSTEM – WATER–COOLED (25 AND 30HP)

<i>key number</i>	<i>description</i>	<i>standard part number</i>	<i>24KT part number</i>	<i>quantity</i>
1	switch, pressure water	250017–992	250017–992	1
2	cover, motor shaft	012266	012266	1
3	nipple, pipe 3/4" x 2 1/2"	822112–025	822112–025	1
4	elbow, 45° 3/4"	801415–030	801415–030	1
5	elbow, 90° tube 3/4" x 3/4"	810512–075	810512–075	3
6	tube, fluid stop	232823	232823	1
7	elbow, tube 1/4" x 1/8"	810504–012	810504–012	2
8	tubing, copper 1/4"	840115–004	840115–004	5 ft.
9	elbow, 90° tube 1/4" x 1/4"	810504–025	810504–025	1
10	elbow, reducing 1" x 3/4"	801604–030	801604–030	2
11	nipple, pipe 1" x 2 1/2"	822216–025	822216–025	2
12	locknut, conduit 1/2"	847200–050	847200–050	1
13	elbow, reducing 1 1/4" x 3/4"	801605–030	801605–030	1
14	filter, fluid (I)	250025–521	250025–521	1
15	bushing, hex 1 1/4" x 3/4"	802105–030	802105–030	1
16	connector, tube 3/4" x 3/4"	810212–075	810212–075	3
17	tube, filter/cooler	221703	221703	1
18	cooler, fluid	043096	043096	1
19	nut, hex ser washer plated 5/16"–18	825305–283	825305–283	4
20	nipple, close 3/4"	822212–000	822212–000	2
21	tee, reducing 3/4" x 1/2" x 3/4"	802203–023	802203–023	1
22	nipple, close 1/2"	822208–000	822208–000	1
23	valve, globe 1/2"	041007	041007	1
24	plug, pipe 1/2"	807800–020	807800–020	1
25	tube, cooler/sump	221705	221705	1
26	screw, hex ser washer 5/16" x 3/4"	829705–075	829705–075	4
27	screw, hex 8.8M10 x 75mm	828010–075	828010–075	2
28	tee, reducing 1" x 1/2" x 1"	802204–024	802204–024	1
29	tie wrap, plastic	843200–025	843200–025	2
30	nipple, pipe 1" x 6"	822116–060	822116–060	1
31	bushing, hex 1/2" x 1/4"	802102–010	802102–010	1
32	tee, reducing 3/4" x 1/2" x 1/2"	802203–022	802203–022	1
33	nipple, pipe 1/2" x 1 1/2"	822108–015	822108–015	2
34	union, pipe 1/2"	802515–020	802515–020	1
35	valve, water regulator 1/2"	041265	041265	1
36	nipple, pipe 1 1/4" x 6"	822120–060	822120–060	1

(continued on Page 15)

(I) For maintenance on fluid filter no. 250025–521, order repair kit no. 250025–525.

PLEASE NOTE: WHEN ORDERING PARTS, INDICATE SERIAL NUMBER OF COMPRESSOR

Section 1
ILLUSTRATIONS AND PARTS LIST

**1.6 COMPRESSOR COOLING AND LUBRICATION SYSTEM – WATER–COOLED (25 AND 30HP)
(Cont'd.)**

<i>key number</i>	<i>description</i>	<i>standard part number</i>	<i>24KT part number</i>	<i>quantity</i>
37	washer, flat $\frac{3}{8}$ "	838206–071	838206–071	2
38	tube, steel $\frac{3}{4}$ " 16 gauge	841115–012	841115–012	1 $\frac{1}{2}$ ft
39	nipple, $\frac{1}{8}$ " x close	823202–000	823202–000	1
40	elbow, $\frac{1}{4}$ " x $\frac{1}{8}$ " FNPT	810404–012	810404–012	1
41	screw, $\frac{5}{16}$ " x $\frac{1}{2}$ "	829705–050	829705–050	2

PLEASE NOTE: WHEN ORDERING PARTS, INDICATE SERIAL NUMBER OF COMPRESSOR

ILLUSTRATIONS AND PARTS LIST

1.7 COMPRESSOR COOLING AND LUBRICATION SYSTEM – WATER-COOLED (40HP)

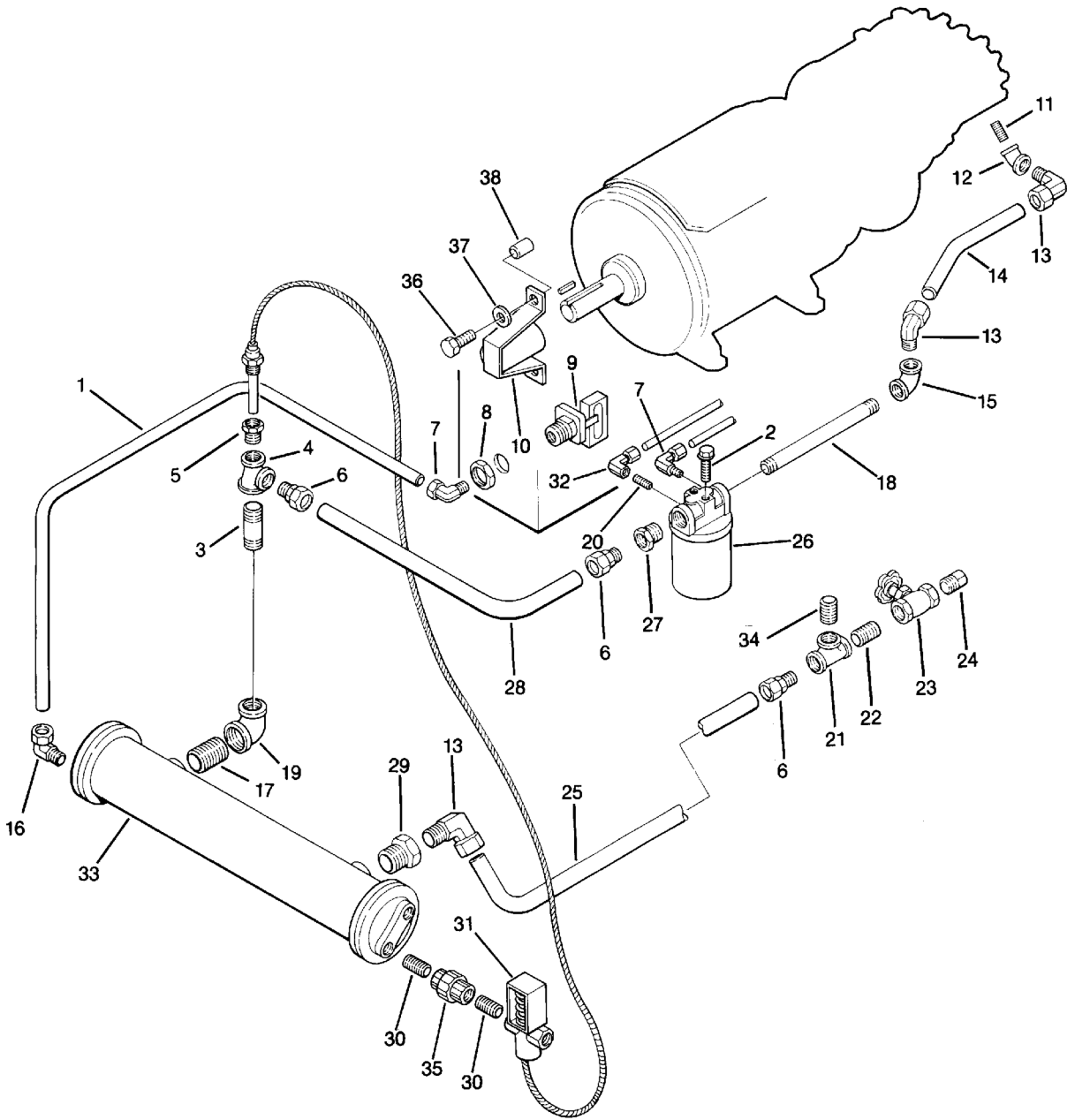

Section 1 ILLUSTRATIONS AND PARTS LIST

1.7 COMPRESSOR COOLING AND LUBRICATION SYSTEM – WATER–COOLED (40HP)

<i>key number</i>	<i>description</i>	<i>standard part number</i>	<i>24KT part number</i>	<i>quantity</i>
1	tubing, copper 1/4"	840115–004	840115–004	6 ft.
2	washer, plain b–regular 3/8"	837206–071	837206–071	20
3	nipple, pipe 1" x 4"	822116–040	822116–040	1
4	tee, reducing 1" x 3/4" x 3/4"	802204–033	802204–033	1
5	bushing, hex 3/4" x 1/2"	802103–020	802103–020	1
6	connector, tube 3/4" x 3/4"	810212–075	810212–075	3
7	elbow, 90° tube 1/4" x 1/8"	810504–012	810504–012	2
8	locknut, conduit 1/2"	847200–050	847200–050	1
9	switch, water pressure	250017–992	250017–992	1
10	cover, motor shaft	014996	014996	1
11	nipple, pipe 3/4" x 2 1/2"	822112–025	822112–025	1
12	elbow, 45° pipe 3/4"	801415–030	801415–030	1
13	elbow, 90° tube 3/4" x 3/4"	810512–075	810512–075	3
14	tube, fluid stop/unit	232823	232823	1
15	elbow, reducing 1 1/4" x 3/4"	801605–030	801605–030	1
16	elbow, 90° tube 1/4" x 3/8"	810504–038	810504–038	1
17	nipple, close 1 1/2" x close	822224–000	822224–000	1
18	nipple, pipe 1" x 6"	822120–060	822120–060	1
19	elbow, reducing 1 1/2" x 1"	801606–040	801606–040	1
20	plate, support	227158	227158	1
21	tee, reducing 3/4" x 1/2" x 3/4"	802203–023	802203–023	1
22	nipple, close 1/2"	822208–000	822208–000	1
23	valve, globe 1/2"	041007	041007	1
24	plug, pipe 1/2" steel	807800–020	807800–020	1
25	tube, sump/oil cooler	227076	227076	1
26	filter, fluid (I)	250025–521	250025–525	1
27	bushing, reducing 1 1/4" x 3/4"	802105–030	802105–030	1
28	tube, oil cooler/filter	227074	227074	1
29	bushing, hex 1 1/2" x 3/4"	802106–030	802106–030	1
30	nipple, pipe 3/4" x 3"	822112–030	822112–030	1
31	valve, water regulator 3/4"	041266	041266	1
32	clamp, retaining 4 1/2"	041983	041983	2
33	heat exchanger 4" x 24"	042657	042657	1
34	nipple, close 3/4"	822212–000	822212–000	3
35	union, 3/4"	802515–030	802515–030	1
36	screw, 8.8M10 x 75mm	828010–075	828010–075	2

(continued on Page 19)

(I) For maintenance on fluid filter no. 250025–521, order repair kit no. 250025–525.

PLEASE NOTE: WHEN ORDERING PARTS, INDICATE SERIAL NUMBER OF COMPRESSOR

ILLUSTRATIONS AND PARTS LIST

1.7 COMPRESSOR COOLING AND LUBRICATION SYSTEM – WATER-COOLED (40HP)

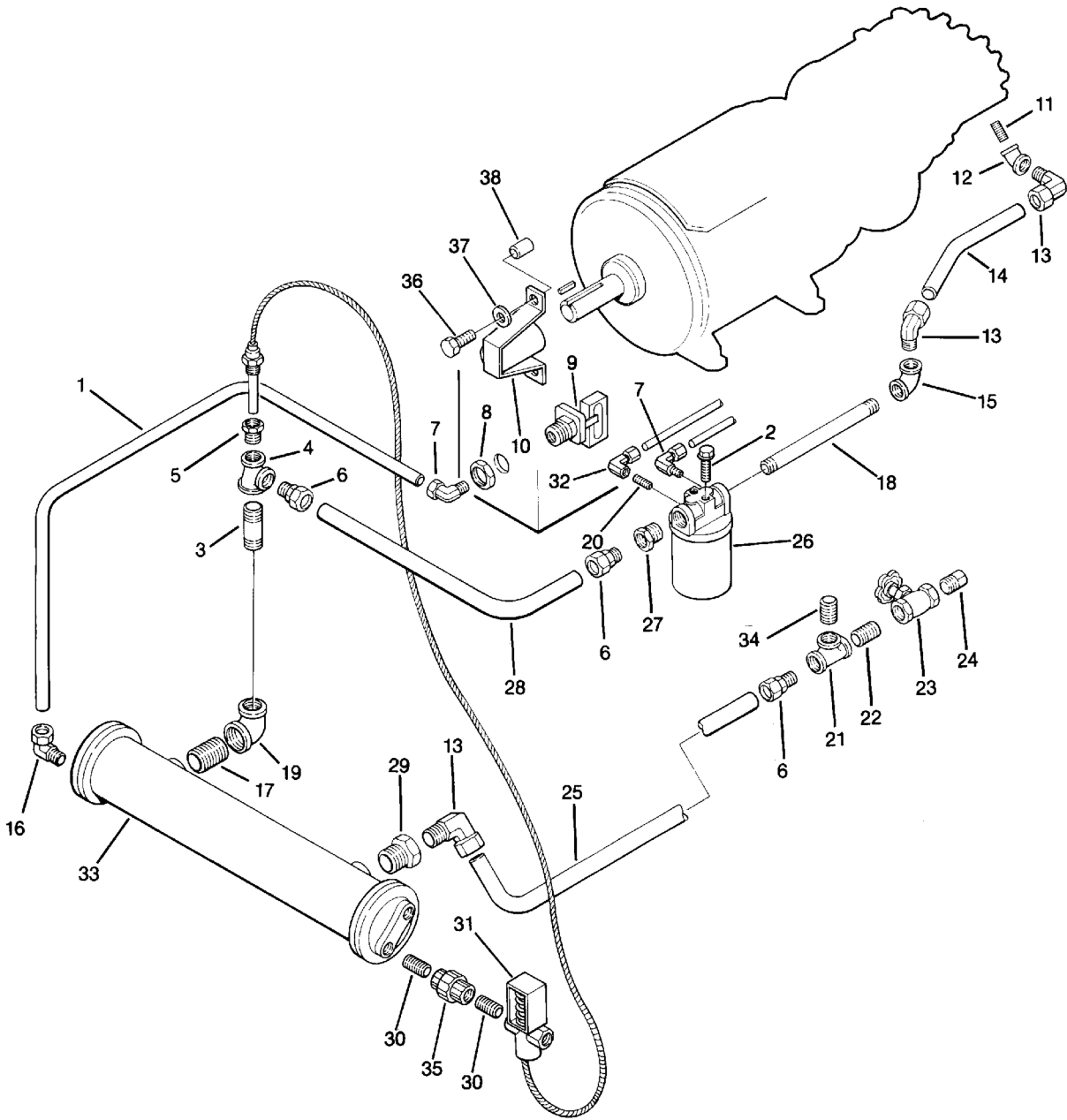

Section 1
ILLUSTRATIONS AND PARTS LIST

1.7 COMPRESSOR COOLING AND LUBRICATION SYSTEM – WATER–COOLED (40HP) (Cont'd.)

<i>key number</i>	<i>description</i>	<i>standard part number</i>	<i>24KT part number</i>	<i>quantity</i>
37	washer, flat $\frac{3}{8}$ "	838206–071	838206–071	2
38	tube, steel $\frac{3}{4}$ " 16 gauge	841115–012	841115–012	1 $\frac{1}{2}$ ft
39	screw, $\frac{5}{16}$ " x $\frac{1}{2}$ "	829705–050	829705–050	2
40	elbow, $\frac{1}{4}$ " x $\frac{1}{8}$ " FNPT	810404–012	810404–012	1
41	nipple, $\frac{1}{8}$ " x close	823202–000	823202–000	1

PLEASE NOTE: WHEN ORDERING PARTS, INDICATE SERIAL NUMBER OF COMPRESSOR

Section 1 ILLUSTRATIONS AND PARTS LIST

1.8 COMPRESSOR DISCHARGE SYSTEM

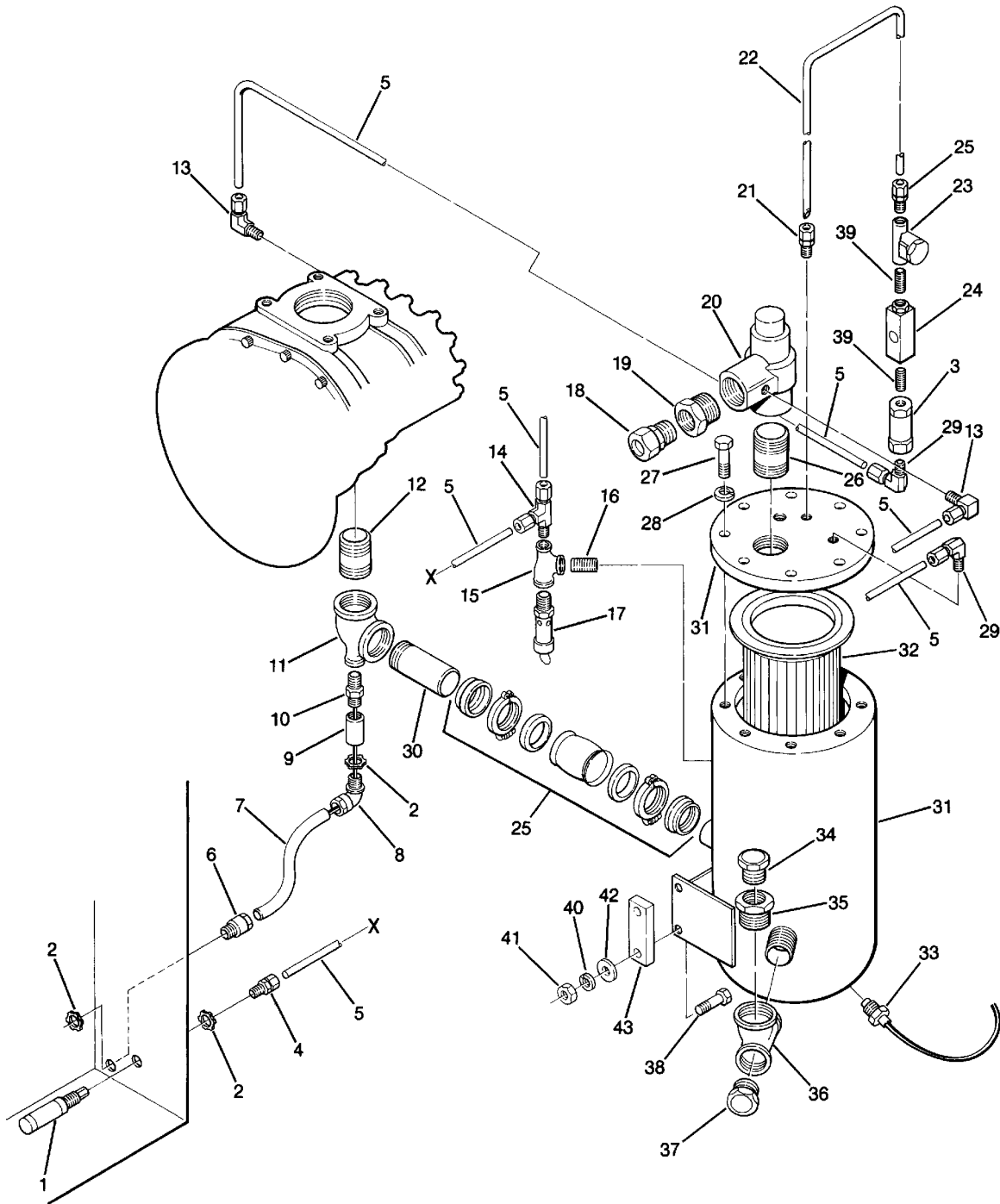

Section 1 ILLUSTRATIONS AND PARTS LIST

1.8 COMPRESSOR DISCHARGE SYSTEM

<i>key number</i>	<i>description</i>	<i>standard part number</i>	<i>24KT part number</i>	<i>quantity</i>
1	switch, pressure 10–250# spot open	250017–991	250017–991	1
2	locknut, conduit ½"	847200–050	847200–050	2
3	valve, check ¼" (I)	049905	049905	1
4	connector, tube–m ¼" x ⅛"	810204–012	810204–012	1
5	tubing, steel ¼" 20 gauge	841115–004	841115–004	6 ft.
6	connector, ½"	846400–050	846400–050	1
7	conduit, ½"	846215–050	846215–050	3
8	elbow, 90° conduit	846600–050	846600–050	1
9	coupling, conduit	250007–179	250007–179	1
10	probe, temperature (24KT)	–	046867	1
	• probe, temperature (std.)	040588	–	1
11	tee, reducing 1½" x ½" x 1½"	802206–026	802206–026	1
12	nipple, close 1½" x close (25 & 30HP)	822224–000	822224–000	1
	• nipple, close 1½" x 3" (40HP)	822124–030	822124–030	1
13	elbow, tube 90° ¼" x ⅛"	810504–012	810504–012	2
14	tee, tube ¼" x ¼"	810904–025	810904–025	1
15	tee, reducing ½" x ¼" x ½"	802202–012	802202–012	1
16	nipple, close ½"	822208–000	822208–000	1
17	valve, pressure relief ½"	250006–938	250006–938	1
18	connector, tube–m 1" x 1"	810216–100	810216–100	1
19	bushing, reducing hex 1¼" x 1"	802105–040	802105–040	1
20	valve, minimum pressure (II)	241581	241581	1
21	connector, flex ¼" x ¼"	020169	020169	1
22	tube, return line	220700	220700	1
23	strainer, v–type (III)	241771	241771	1
24	glass, oil sight	046559	046559	1
25	coupling, flexible (std.) (IV)	040033	–	1
	• coupling, flexible (24KT) (V)	–	250007–544	1
26	nipple, pipe 1¼" x 2½"	822120–025	822120–025	1
27	capscrew, hex gr5 ½"–13 x 1¼"	828608–125	828608–125	8
28	washer, springlock ½"	837508–125	837508–125	8
29	elbow, tube–m 90° ¼" x ¼"	810504–025	810504–025	1

(continued on Page 23)

(I) For maintenance on check valve no. 049905, order replacement spring no. 250003–657.

(II) For maintenance on minimum pressure valve no. 241581, order seal kit no. 250026–758.

(III) For maintenance on v–type strainer no. 241771, order repair kit no. 241772.

(IV) For maintenance on flexible coupling no. 040033, order gasket kit no. 040517.

(V) For maintenance on flexible coupling no. 250007–544, order gasket kit no. 250007–559.

PLEASE NOTE: WHEN ORDERING PARTS, INDICATE SERIAL NUMBER OF COMPRESSOR

Section 1 ILLUSTRATIONS AND PARTS LIST

1.8 COMPRESSOR DISCHARGE SYSTEM

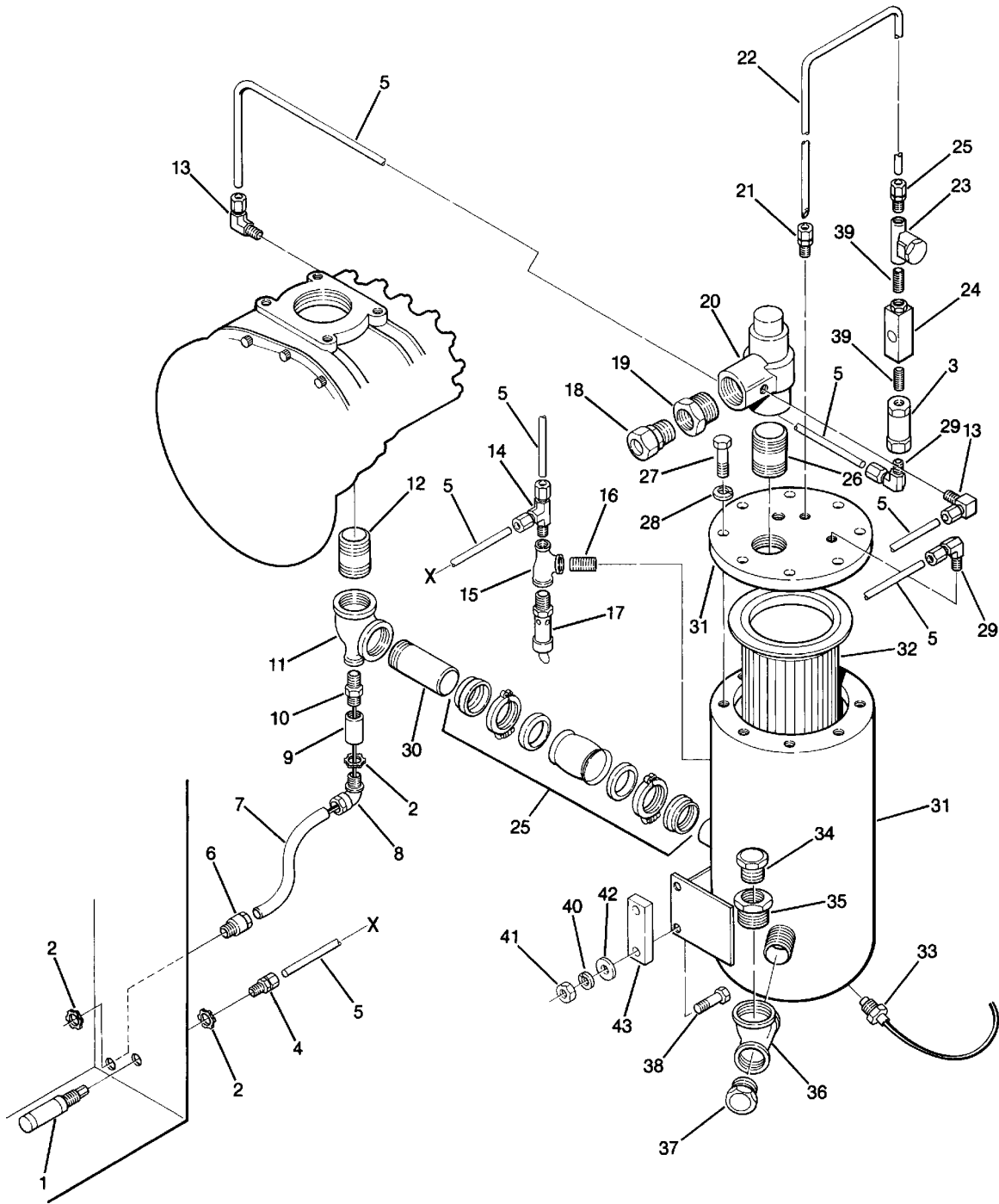

Section 1

ILLUSTRATIONS AND PARTS LIST

1.8 COMPRESSOR DISCHARGE SYSTEM (continued)

<i>key number</i>	<i>description</i>	<i>standard part number</i>	<i>24KT part number</i>	<i>quantity</i>
30	nipple, half 1 1/2" x 5 1/2"	822824-055	822824-055	1
31	tank, sump	047070	047070	1
32	element, separator (25 & 30HP) (II)	250034-111	250034-113	1
	• element, separator (40HP) (I) (II)	250034-111	250034-113	1
33	gauge, temperature 2"	042582	042582	1
34	cap, fluid fill	040029	040029	1
35	adapter, fill cap	020044	020044	1
36	tee, reducing 1" x 1" x 1 1/2"	802204-046	802204-046	1
37	glass, sight	041327	041327	1
38	capscrew, hex head gr8 1/2"x1 1/2" (25,30HP)	828608-150	828608-150	2
	•capscrew, 1/2"-13 x 2 1/4" (40HP)	828608-225	828608-225	2
39	nipple, close 1/4" 6aw galv	823204-000	823204-000	2
40	washer, springlock 1/2"	837508-125	837508-125	2
41	nut, hex 1/2"-13	824208-448	824208-448	2
42	washer, 1/2" flat	838208-112	838208-112	2
43	spacer (40HP)	232684	232684	129

(I) For maintenance on separator element (std.) no. 250034-111, order repair kit no. 250034-112.

(II) For maintenance on separator element (24KT) no. 250034-113, order repair kit no. 250034-114.

PLEASE NOTE: WHEN ORDERING PARTS, INDICATE SERIAL NUMBER OF COMPRESSOR

Section 1 ILLUSTRATIONS AND PARTS LIST

1.9 ELECTRICAL BOX

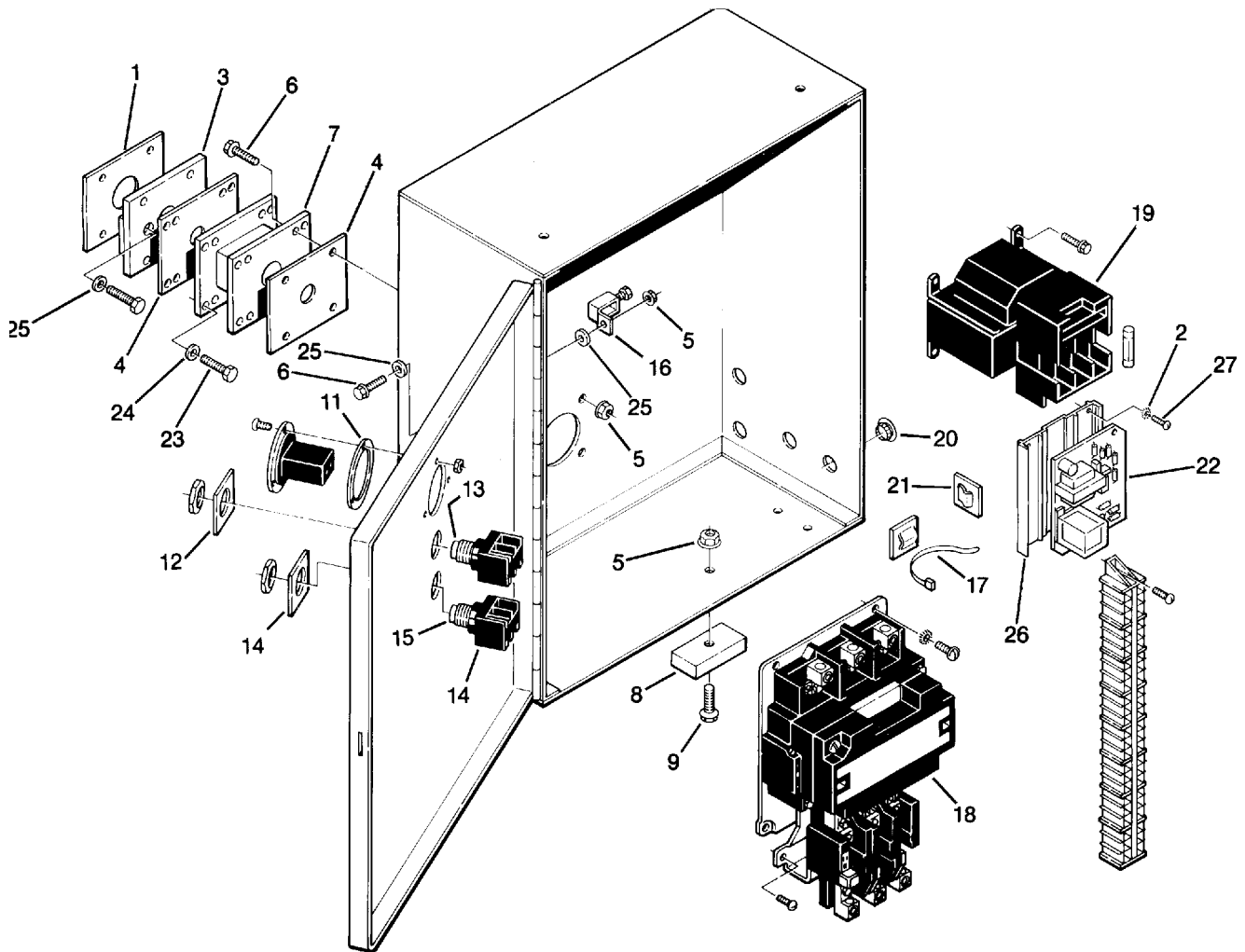

Section 1 ILLUSTRATIONS AND PARTS LIST

1.9 ELECTRICAL BOX

<i>key number</i>	<i>description</i>	<i>standard part number</i>	<i>24KT part number</i>	<i>quantity</i>
1	gasket, motor/starter mount (25 & 30HP)	250030-147	250030-147	1
	• gasket, motor/starter mount (40HP)	405159	405159	1
2	washer, #10 external tooth	838402-025	838402-025	2
3	adaptor, motor (25 & 30HP)	250027-818	250027-818	1
	• adaptor, motor (40HP)	250027-890	250027-890	1
4	gasket, starter	220790	220790	2
5	nut, hex 5/16"-18	825305-283	825305-283	7
6	screw, 5/16"-18 x 3/4" (25, 30HP)	829705-075	829705-075	7
	•screw, 5/16"-18 x 3/4" (40HP)	829705-075	829705-075	5
7	adapter, motor/starter (25, 30HP)	250021-278	250021-278	1
8	bar, 1" x 2" x 3" (40HP)	040632	040632	2
9	screw, serrated washer 5/16"-18 x 3/4" (25, 30HP)	829705-075	829705-075	2
	•screw, serrated washer 5/16"-18 x 1 1/2" (40HP)	829705-150	829705-150	2
10	hourmeter, 2 1/2" 120V 60Hz	042988	042988	1
11	gasket, hourmeter	410353	410353	1
12	nameplate, START	250023-049	250023-049	1
13	pushbutton, START assembly	250016-351	250016-351	1
14	nameplate, STOP	250023-050	250023-050	1
15	pushbutton, STOP assembly	250016-350	250016-350	1
16	lug, scrulug 4 str 1/0 str 5/16"	849215-025	849215-025	1
17	wrap, tie plastic 26m 1/16" x 1 3/4"	843200-025	843200-025	2
18	starter, N3 open	052362	052362	1
	• starter, N4 open	052036	052036	1
19	transformer, 380/416V	250028-878	250028-878	1
	• transformer, 208V	250028-872	250028-872	1
	• transformer, 230/460V	250028-721	250028-721	1
	• transformer, 600V	250028-884	250028-884	1
20	plug, hole 1/2"	045689	045689	2
21	clip, plastic	041632	041632	2
22	control, temperature (KT only)	-	409270	1
23	screw, 3/8" x 16 x 3/4" (25, 30HP)	828606-075	828606-075	4
24	washer, 3/8" springlock (25, 30HP)	837506-094	837506-094	4
25	washer, 5/16" external tooth	838405-034	838405-034	6
26	track, snap mounting	250024-522	250024-522	1
27	screw, 8-32 x 1/2"	835601-050	635601-050	2

PLEASE NOTE: WHEN ORDERING PARTS, INDICATE SERIAL NUMBER OF COMPRESSOR

Section 1 ILLUSTRATIONS AND PARTS LIST

1.10 PNEUMATIC CONTROLS

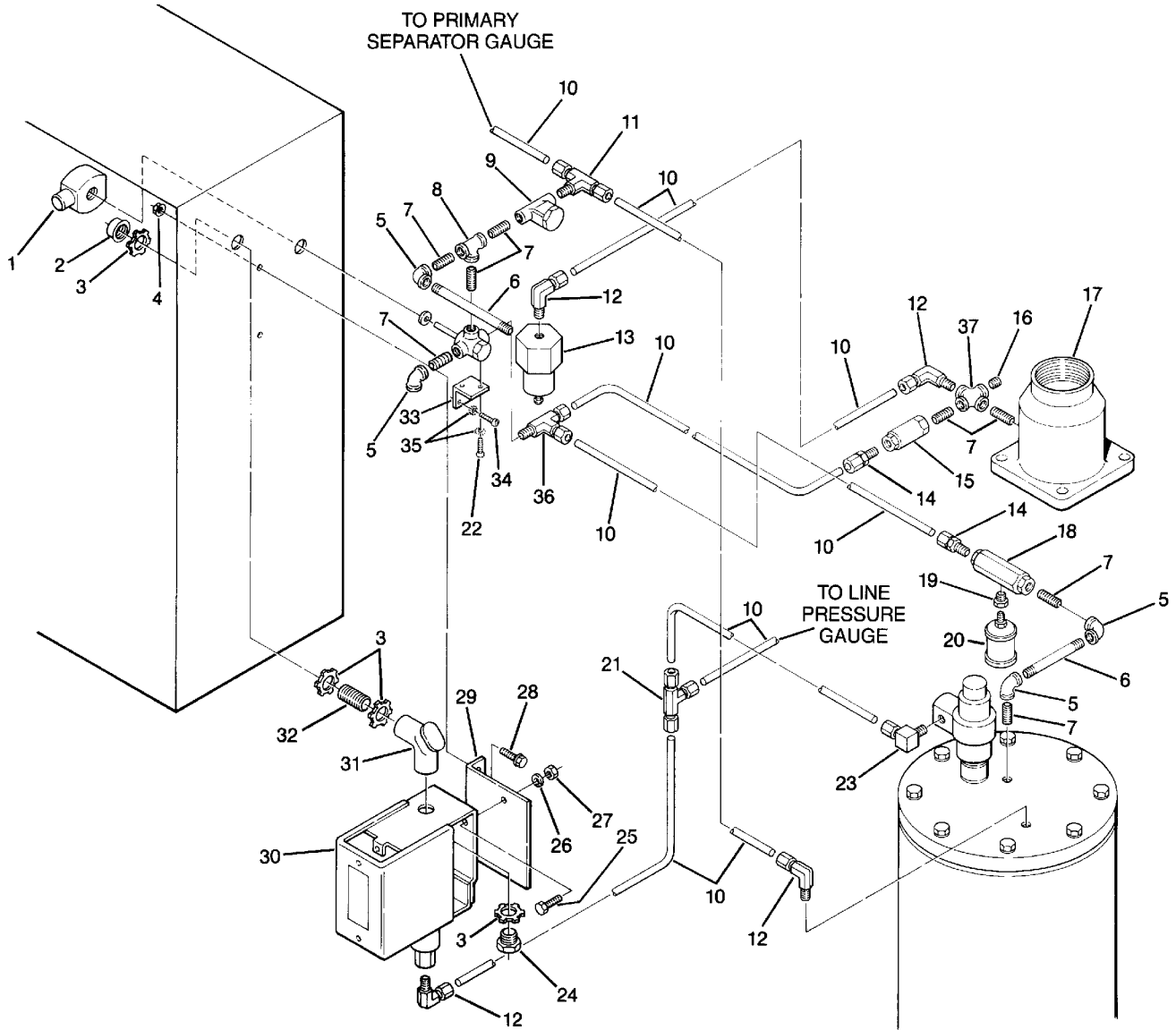

Section 1 ILLUSTRATIONS AND PARTS LIST

1.10 PNEUMATIC CONTROLS

<i>key number</i>	<i>description</i>	<i>standard part number</i>	<i>24KT part number</i>	<i>quantity</i>
1	valve, solenoid ¼" 3-way (I)	250017-993	250017-993	1
2	bushing, conduit plastic ½"	848815-050	848815-050	1
3	locknut, conduit ½"	847200-050	847200-050	4
4	nut, hex serrated washer 5/16"	825305-283	825305-283	2
5	elbow, pipe 90° ¼"	803515-010	803515-010	4
6	nipple, pipe ¼" x 4½"	823104-045	823104-045	1
7	nipple, pipe ¼" x close	823204-000	823204-000	8
8	tee, pipe ¼"	804415-010	804415-010	1
9	strainer, v-type (II)	241771	241771	1
10	tubing, steel ¼"	841015-004	841015-004	6 ft.
11	tee, tube-m ¼" x ¼" x ¼"	810804-025	810804-025	1
12	elbow, tube-m ¼" x ¼"	810504-025	810504-025	3
13	valve, pressure regulator (III)	250017-280	250017-280	1
14	connector, tube-m ¼" x ¼"	810204-025	810204-025	2
15	valve, check ¼"	049905	049905	1
16	orifice, pipe plug ¼"	232874	232874	1
17	valve, air inlet 2½" (IV)	250025-654	250025-654	1
18	valve, blowdown ¼" (V)	250025-655	250025-655	1
19	bushing, reducing ¼" x ⅛"	807600-005	807600-005	1
20	silencer, ⅛"	043196	043196	1
21	tee, tube union ¼"	811404-025	811404-025	1
22	screw, 8-32 x 3/8"	835601-038	835601-038	2
23	elbow, tube-m ¼" x ⅛"	810504-012	810504-012	1
24	nipple, chase conduit ½"	847815-050	847815-050	1
25	screw, 10-32 x ½"	831702-050	831702-050	2
26	washer, springlock #10	838502-047	838502-047	2
27	nut, 10-32	825801-130	825801-130	2
28	screw, hex serrated washer 5/16" x 3/4"	829705-075	829705-075	2
29	bracket, pressure switch	250018-146	250018-146	1
30	switch, pressure	040694	040694	1

(continued on Page 29)

(I) For maintenance on solenoid valve no. 250017-993, order repair kit no. 250018-970.

(II) For maintenance on v-type strainer no. 241771, order repair kit no. 241772.

(III) For maintenance on pressure regulator valve no. 250017-280, order repair kit no. 250019-453.

(IV) For maintenance on air inlet valve no. 250025-654, order repair kit no. 250019-451.

(V) For maintenance on blowdown valve no. 250025-655, order repair kit no. 250031-772.

PLEASE NOTE: WHEN ORDERING PARTS, INDICATE SERIAL NUMBER OF COMPRESSOR

Section 1 ILLUSTRATIONS AND PARTS LIST

1.10 PNEUMATIC CONTROLS

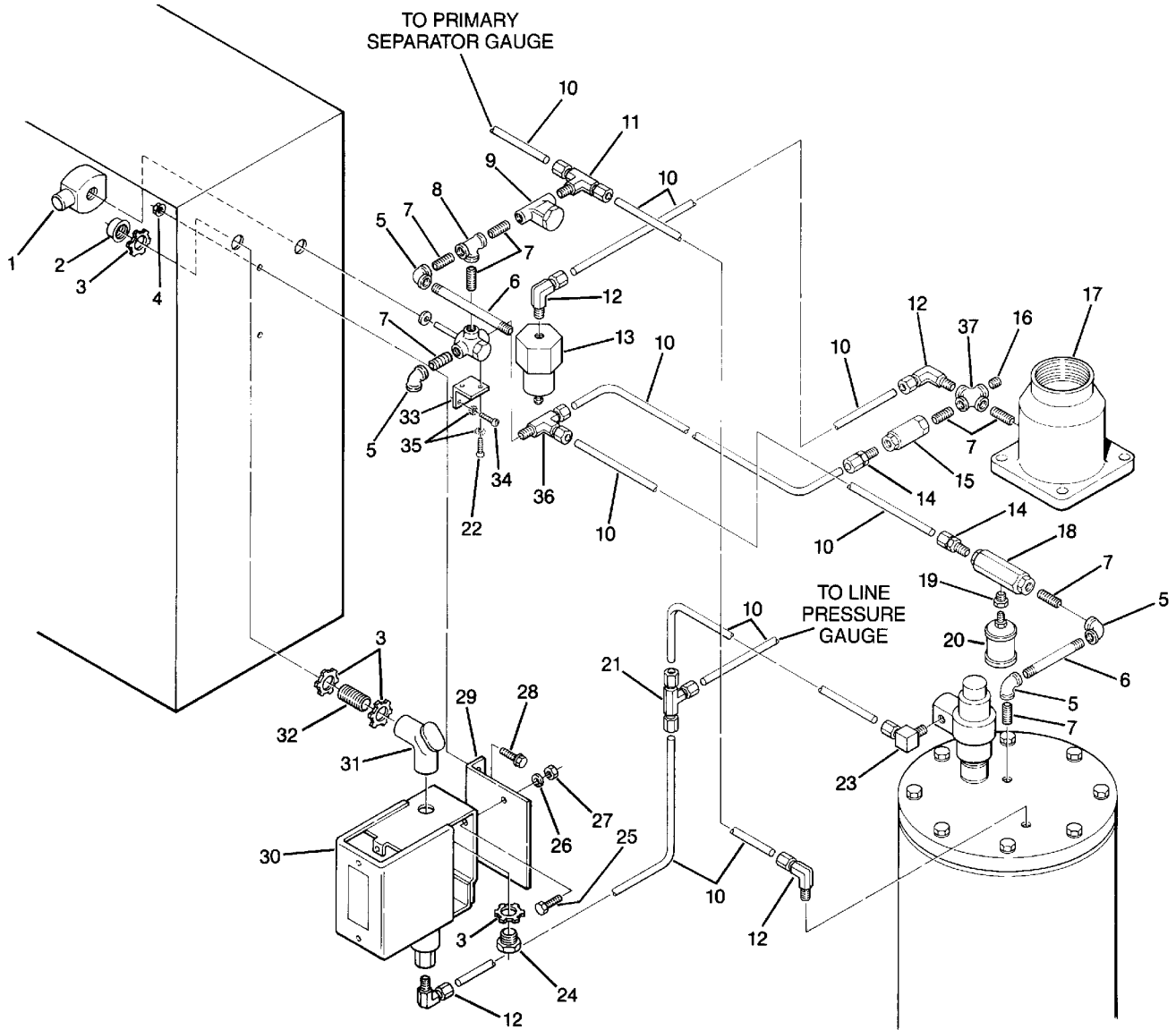

Section 1
ILLUSTRATIONS AND PARTS LIST

1.10 PNEUMATIC CONTROLS (continued)

<i>key number</i>	<i>description</i>	<i>standard part number</i>	<i>24KT part number</i>	<i>quantity</i>
31	elbow, corner pull 90° ½"	846915-050	846915-050	1
32	nipple, conduit ½" x ½"	250007-169	250007-169	3
33	bracket, solenoid valve support	250030-037	250030-037	1
34	screw, tc-f pan #10-24 x ½"	835602-050	835602-050	2
35	washer, loc ext #10	838402-025	838402-025	4
36	tee, tube m-run ¼" x ¼"	810904-025	810904-025	1
37	pipe, cross ¼"	803315-010	803315-010	1

PLEASE NOTE: WHEN ORDERING PARTS, INDICATE SERIAL NUMBER OF COMPRESSOR

Section 1

ILLUSTRATIONS AND PARTS LIST

1.11 INSTRUMENT PANEL -- OPEN AND ENCLOSURE OPTION

<i>key number</i>	<i>description</i>	<i>standard part number</i>	<i>24KT part number</i>	<i>quantity</i>
1	gauge, temperature	042582	042582	1
2	gauge, air pressure	250005-185	250005-185	2
3	gauge, separator maintenance	250003-798	250003-798	1
4	gauge, fluid filter maintenance	250003-799	250003-799	1
5	panel, instrument (open)	250003-873	250003-873	1
6	connector, tube-f $\frac{1}{4}$ " x $\frac{1}{8}$ "	810104-012	810104-012	5
7	tee, tube-f run $\frac{1}{4}$ " x $\frac{1}{8}$ "	811004-012	811004-012	1
8	nut, hex serrated washer plated $\frac{5}{16}$ "-18	825305-283	825305-283	2
9	screw, hex serrated washer $\frac{5}{16}$ " x $\frac{3}{4}$ "	829705-075	829705-075	2
10	tubing, steel $\frac{1}{4}$ "	840115-004	840115-004	10
11	label, instrument panel	250004-977	250004-977	1

PLEASE NOTE: WHEN ORDERING PARTS, INDICATE SERIAL NUMBER OF COMPRESSOR

Section 1 ILLUSTRATIONS AND PARTS LIST

1.12 AIR-COOLED AFTERCOOLING OPTION (25 AND 30HP)

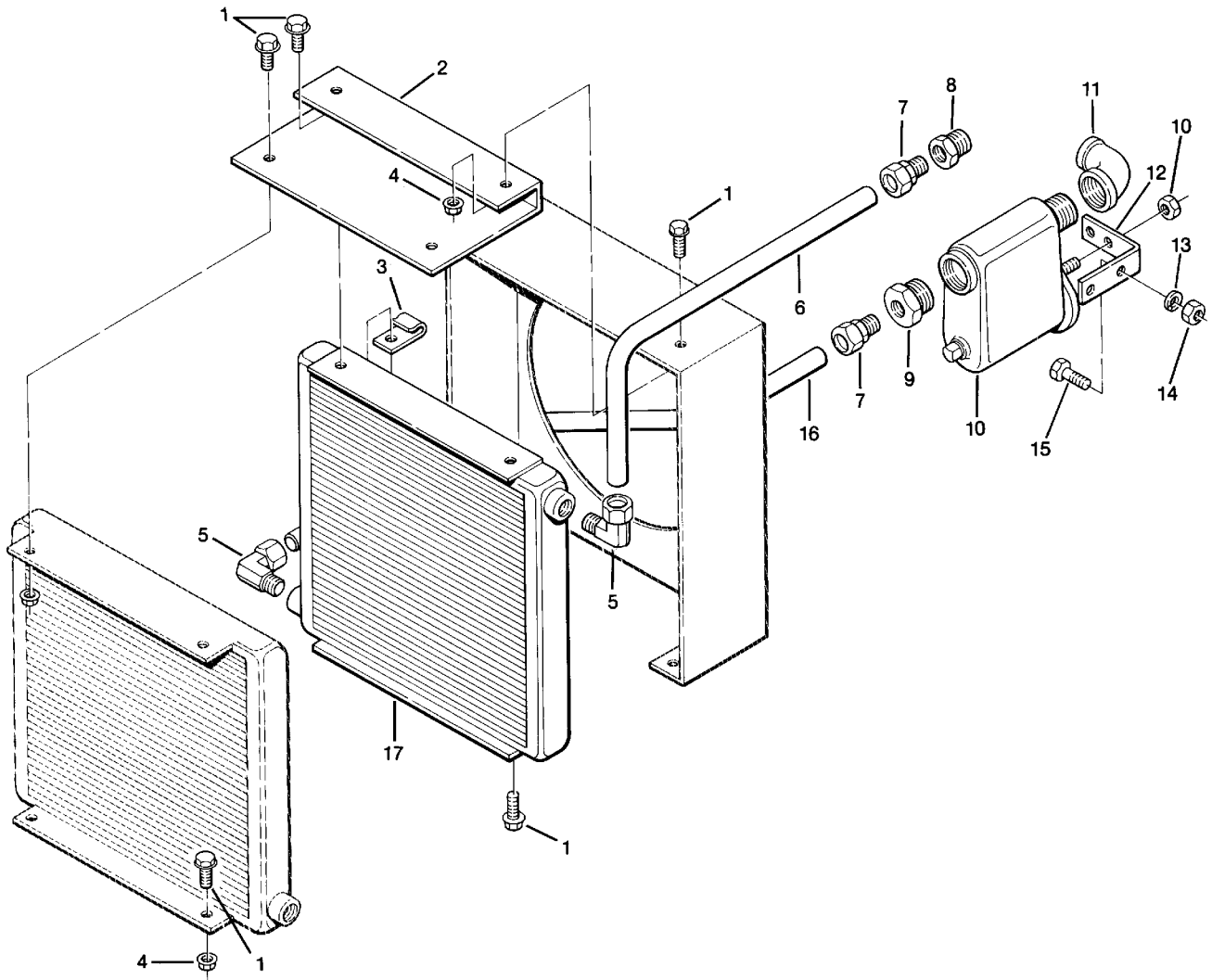

Section 1 ILLUSTRATIONS AND PARTS LIST

1.12 AIR-COOLED AFTERCOOLING OPTION (25 AND 30HP)

<i>key number</i>	<i>description</i>	<i>standard part number</i>	<i>24KT part number</i>	<i>quantity</i>
1	screw, hex head ser wash $\frac{5}{16}$ " x $\frac{3}{4}$ "	829705-075	829705-075	6
2	panel, cooler adapter	224076	224076	1
3	nut, retainer "J" $\frac{5}{16}$ "-18	861405-092	861405-092	4
4	nut, hex serrated wash plated $\frac{5}{16}$ "-18	825305-283	825305-283	2
5	elbow, 1" x $\frac{3}{4}$ " mnpt (25, 30HP)	810516-075	810516-075	2
	•elbow, 90° tube 1" x 1" (40HP)	810516-100	810516-100	2
6	tube, aftercooler/check valve (25, 30HP)	221700	221700	1
	• tube, aftercooler/check valve (40HP)	250026-954	250026-954	1
7	connector, tube 1" x 1"	810216-100	810216-100	2
8	bushing, hex $1\frac{1}{4}$ " x 1"	802105-040	802105-040	1
9	bushing, hex 2" x 1"	802108-040	802108-040	1
10	separator/trap (I)	040847	040847	1
11	elbow, reducing 2" x $1\frac{1}{2}$ "	801608-060	801608-060	1
12	bracket, mount trap	021481	021481	1
13	washer, springlock regular $\frac{1}{2}$ "	837508-125	837508-125	2
14	nut, hex $\frac{1}{2}$ "-13	824208-448	824208-448	2
15	capscrew, hex head gr5 $\frac{1}{2}$ " x $1\frac{1}{2}$ "	828608-150	828608-150	2
16	tube, aftercooler/separator (25, 30HP)	232968	232968	1
	• tube, aftercooler/separator (40HP)	250026-955	250026-955	1
17	aftercooler, (25, 30HP)	407106	407106	1
	• aftercooler, (40HP)	241852	241852	1

(I) For maintenance on separator/trap no. 040847, order repair kit no. 044374.

PLEASE NOTE: WHEN ORDERING PARTS, INDICATE SERIAL NUMBER OF COMPRESSOR

Section 1

ILLUSTRATIONS AND PARTS LIST

1.13 WATER-COOLED AFTERCOOLING OPTION (25 AND 30HP)

<i>key number</i>	<i>description</i>	<i>standard part number</i>	<i>24KT part number</i>	<i>quantity</i>
1	bracket, mount trap	021481	021481	1
2	separator/trap (I)	040847	040847	1
3	heat exchanger	043096	043096	1
4	tube, aftercooler/oil cooler	221699	221699	1
5	tube, aftercooler/separator	250026-956	250026-956	1
6	tube, MPV/aftercooler	232829	232829	1
7	elbow, 90° pipe 1"	801515-040	801515-040	1
8	elbow, reducing 2" x 1½"	801608-060	801608-060	1
9	bushing, hex 1¼" x 1"	802105-040	802105-040	1
10	bushing, hex 2" x 1"	802108-040	802108-040	1
11	connector, tube 5⁄8" x ½"	810210-050	810210-050	2
12	connector, tube 1" x 1"	810216-100	810216-100	3
13	elbow, 90° tube 1" x 1"	810516-100	810516-100	1
14	nipple, pipe 1" x 5"	822116-050	822116-050	1
15	nut, hex ½" - 13	824208-448	824208-448	2
16	nut, hex serrated washer 5⁄16" - 18	825305-283	825305-283	4
17	capscrew, hex gr5 ½" x 1½"	828608-150	828608-150	2
18	screw, hex serrated washer 5⁄16" x ¾"	829705-075	829705-075	4
19	washer, springlock regular ½"	837508-125	837508-125	2
20	cap, inlet-outlet	044244	044244	1
21	cap, reversing	044245	044245	1
22	gasket, inlet-outlet	044242	044242	1
23	gasket, reversing cap	044243	044243	1
24	bushing, reducing ¾" x ½"	802103-020	802103-020	2

(I) For maintenance on separator/trap no. 040847, order repair kit no. 043374.

PLEASE NOTE: WHEN ORDERING PARTS, INDICATE SERIAL NUMBER OF COMPRESSOR

Section 1
ILLUSTRATIONS AND PARTS LIST

1.14 WATER-COOLED AFTERCOOLING OPTION (40HP)

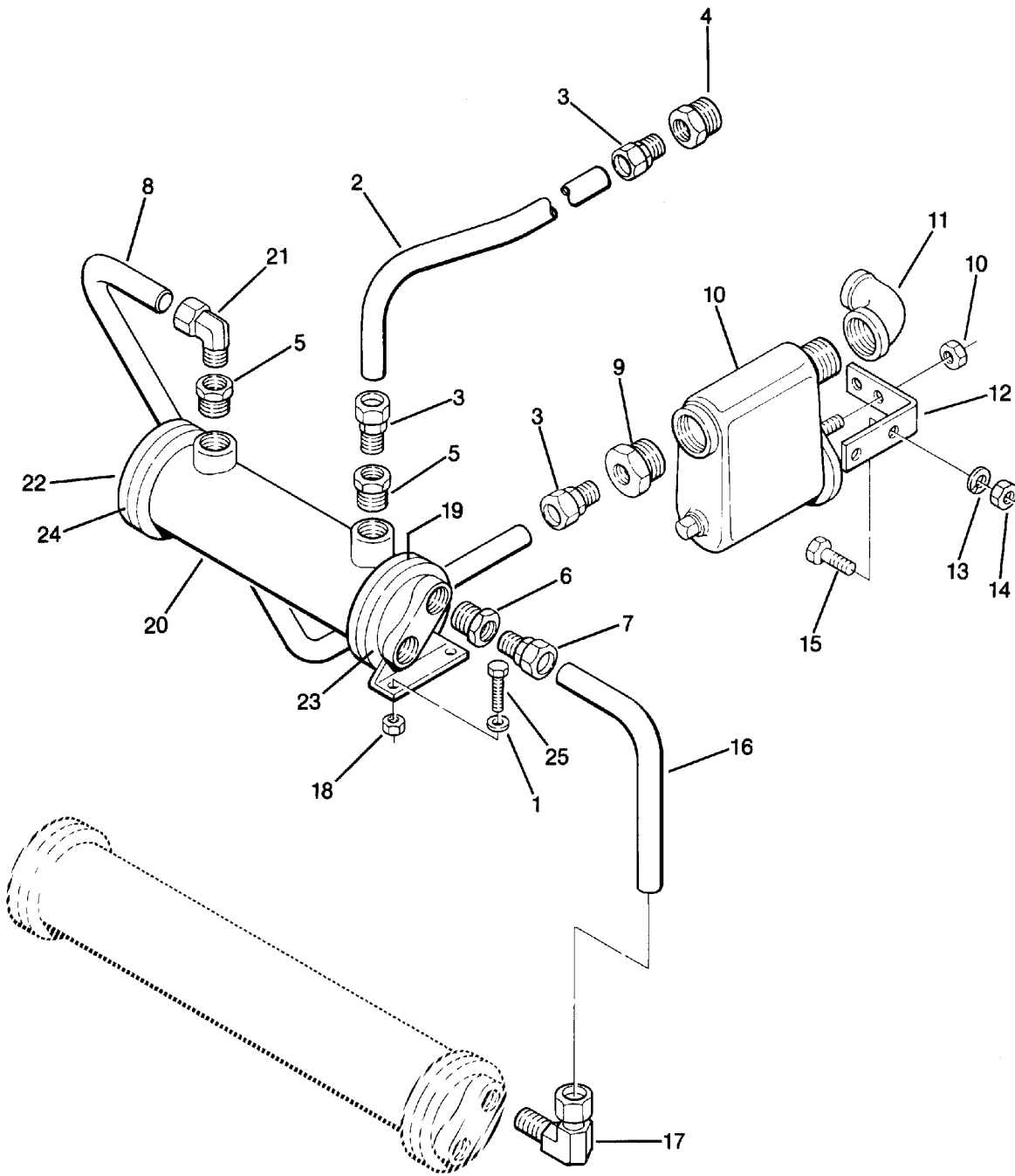

Section 1

ILLUSTRATIONS AND PARTS LIST

1.14 WATER-COOLED AFTERCOOLING OPTION (40HP)

<i>key number</i>	<i>description</i>	<i>standard part number</i>	<i>24KT part number</i>	<i>quantity</i>
1	washer, flat $\frac{3}{8}$ "	838206-071	838206-071	4
2	tube, MPV/aftercooler	227075	227075	1
3	connector, tube 1" x 1"	810216-100	810216-100	3
4	bushing, hex $1\frac{1}{4}$ " x 1"	802105-040	802105-040	1
5	bushing, hex $1\frac{1}{2}$ " x 1"	802106-040	802106-040	2
6	bushing, hex 1" x $\frac{3}{4}$ "	802104-030	802104-030	1
7	connector, tube $\frac{3}{4}$ " x $\frac{3}{4}$ "	810212-075	810212-075	1
8	tube, separator/aftercooler	227077	227077	1
9	bushing, hex 2" x 1"	802108-040	802108-040	1
10	separator/trap (I) • heater (optional)	040847 245572	040847 245572	1 1
11	elbow, reducing 2" x $1\frac{1}{2}$ "	801608-060	801608-060	1
12	bracket, mount trap	021481	021481	1
13	washer, springlock regular $\frac{1}{2}$ "	837508-125	837508-125	4
14	nut, hex $\frac{1}{2}$ "-13	824208-448	824208-448	2
15	capscrew, hex head gr5 $\frac{1}{2}$ " x $1\frac{1}{2}$ "	828608-150	828608-150	2
16	tube, aftercooler/oil cooler	227078	227078	1
17	elbow, $\frac{3}{4}$ " x $\frac{3}{4}$ " mnpt	810212-075	810212-075	1
18	nut, $\frac{5}{16}$ "-18	825305-283	825305-283	4
19	gasket, reversing cap	044221	044221	1
20	heat exchanger	043062	043062	1
21	elbow, tube 1" x 1"	810516-100	810516-100	1
22	cap, inlet-outlet	044229	044229	1
23	cap, reversing	044228	044228	1
24	gasket, inlet-outlet cap	044220	044220	1
25	screw, $\frac{5}{16}$ " x $\frac{3}{4}$ "	829705-075	829705-075	4

(I) For maintenance on separator/trap no. 040847, order repair kit no. 044374.

PLEASE NOTE: WHEN ORDERING PARTS, INDICATE SERIAL NUMBER OF COMPRESSOR

Section 1 ILLUSTRATIONS AND PARTS LIST

1.15 WATER-COOLED AND AIR-COOLED ENCLOSURE AND PARTS – OPTION

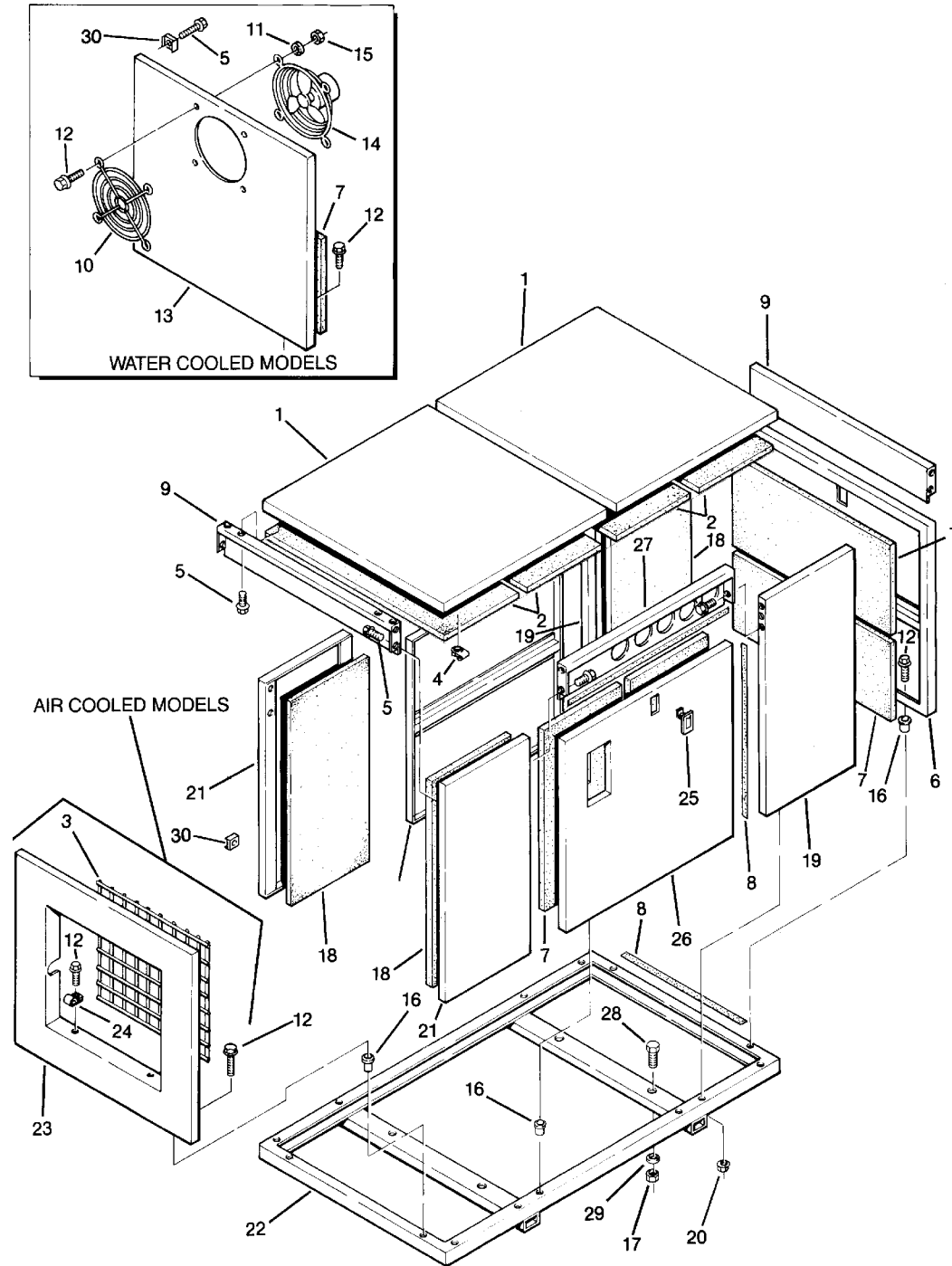

Section 1 ILLUSTRATIONS AND PARTS LIST

1.15 WATER-COOLED AND AIR-COOLED ENCLOSURE AND PARTS – OPTION

<i>key number</i>	<i>description</i>	<i>standard part number</i>	<i>24KT part number</i>	<i>quantity</i>
1	panel, roof	250018-316	250018-316	2
2	panel, fiberglass 5" x 35½"	049889-035	049889-035	4
3	grill, cooler (air-cooled)	242095	242095	1
4	nut, retainer "J" 5/16" – 18 u-clip	861505-140	861505-140	14
5	screw, hex serrated washer 5/16" x 3/4" (air-cooled)	829705-075	829705-075	40
	• screw, hex serrated washer 5/16" x 3/4" (water-cooled)	829705-075	829705-075	36
6	panel, access	014620	014620	2
7	panel, fiberglass 15¼" x 32½" (air-cooled)	049889-005	049889-005	6
	• panel, fiberglass 15¼" x 32½" (water-cooled)	049889-005	049889-005	7
8	weatherstrip, felt	043502	043502	75 ft.
9	panel, enclosure center	224585	224585	3
10	guard, fan 13"	241579	241579	1
11	washer, springlock regular ¼" (AC)	837504-062	837504-062	6
	• washer, springlock regular ¼" (WC)	837504-062	837504-062	12
12	capscrew, hex head gr5 ¼" – 20 x 1" (air-cooled)	829104-100	829104-100	6
	• capscrew, hex head gr5 ¼" – 20 x 1" (water-cooled)	829104-100	829104-100	12
13	panel, end	02250043-677	02250043-677	1
14	fan, enclosure	241580	241580	1
15	nut, hex ¼" – 20	824204-226	824204-226	4
16	rivet, tubular ¼" – 20	049824	049824	8
17	nut, hex ½" – 13	824208-448	824208-448	4
18	panel, fiberglass 13" x 36½"	049889-012	049889-012	4
19	panel, enclosure – right hand	224583	224583	2
20	nut, hex serrated washer pltd 5/16" – 18 (air-cooled)	825305-283	825305-283	28
	nut, hex serrated washer pltd 5/16" – 18 (water-cooled)	825305-283	825305-283	24
21	panel, enclosure – left hand	224584	224584	2
22	frame, enclosure	014790	014790	1
23	panel, cooler end (air-cooled)	014812	014812	1
24	clamp, speed ¼" (air-cooled)	043194	043194	4
25	latch, door (air-cooled)	049764	049764	3
	latch, door (water-cooled)	049764	049764	5
26	panel, access	250018-708	250018-708	1
27	panel, enclosure front	250003-872	250003-872	1
28	capscrew, hex head gr5 ½" x 1½"	828608-150	828608-150	4
29	washer, springlock regular ½"	837508-125	837508-125	4
30	nut, retainer (air-cooled)	861405-092	861405-092	4

PLEASE NOTE: WHEN ORDERING PARTS, INDICATE SERIAL NUMBER OF COMPRESSOR

Section 1
ILLUSTRATIONS AND PARTS LIST

1.16 HEAVY DUTY FILTER OPTION

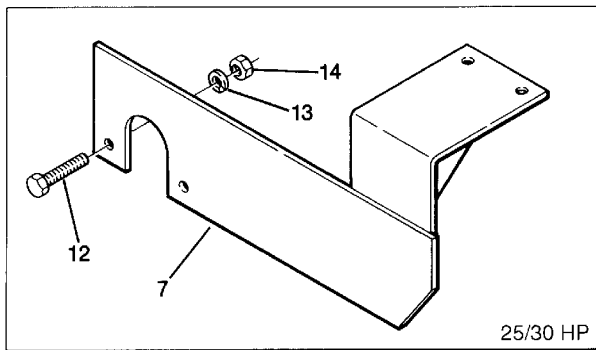
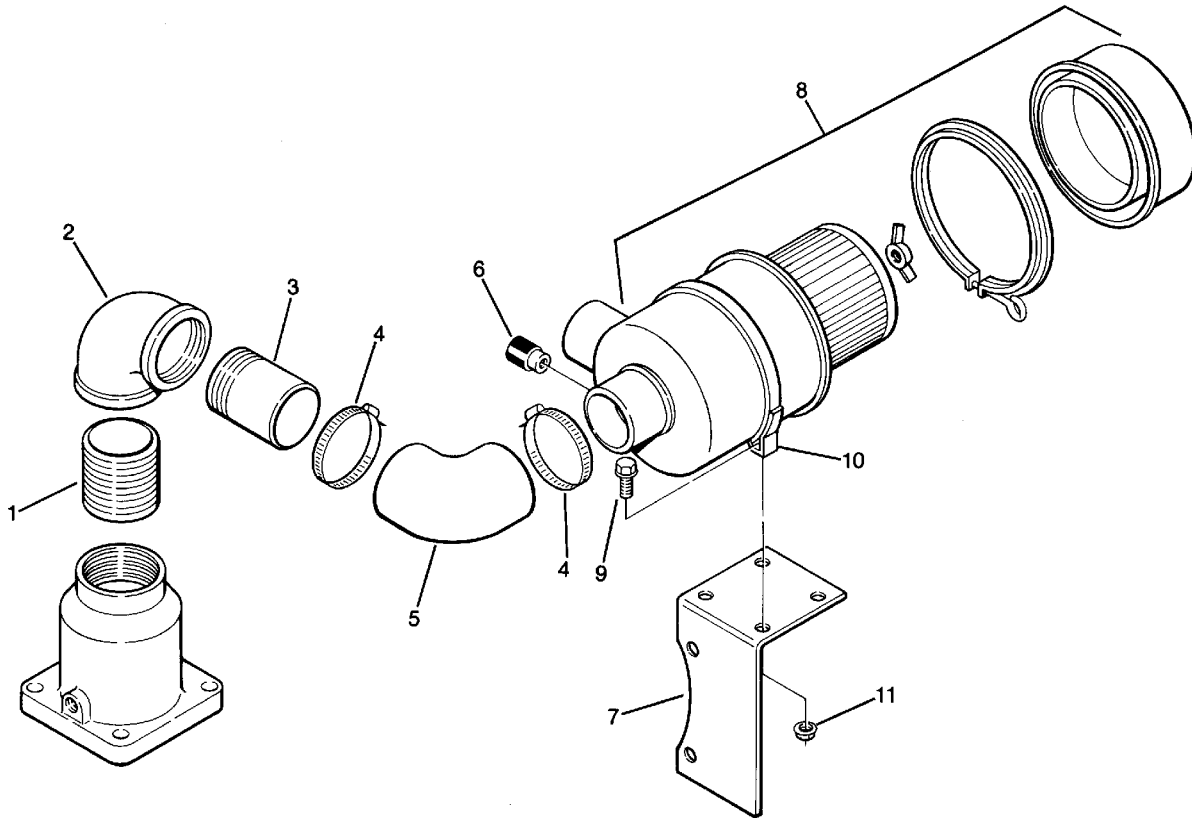

Section 1 ILLUSTRATIONS AND PARTS LIST

1.16 HEAVY DUTY FILTER OPTION

<i>key number</i>	<i>description</i>	<i>standard part number</i>	<i>24KT part number</i>	<i>quantity</i>
1	nipple, close 2½"	822240-000	822240-000	1
2	elbow, reducing 2½" x 2" (25, 30HP) • elbow, pipe 90° 2½" (40HP)	801610-080 801515-100	801610-080 801515-100	1 1
3	nipple, half 2" x 3" (25, 30HP) • nipple half 2½" x 3" (40HP)	822832-030 822840-030	822832-030 822840-030	1 1
4	clamp, hose 1⅞" x 2¾" (25, 30HP) • clamp, hose 3" (40HP)	040083 040343	040083 040343	2 2
5	elbow, rubber (25, 30HP) • elbow, rubber (40HP)	044634 041960	044634 041960	1 1
6	indicator, air filter maintenance	045757	045757	1
7	support, air filter (25, 30HP) • bracket, air filter (40HP)	250042-848 015718	250042-848 015718	1 1
8	filter, air (25, 30HP) (I) • filter, air (40HP) (II)	043333 040595	043333 040595	1 1
9	screw, hex serrated washer 5/16" x 3/4"	829705-075	829705-075	2
10	band, mounting (25, 30HP) • band, mounting (40 HP)	043370 040598	043370 040598	1 1
11	nut, hex serrated washer plated 5/16"-16	825305-283	825305-283	2
12	capscrew, hex head gr5 3/8" x 1¼" (25, 30HP)	828606-125	828606-125	2
13	washer, springlock regular 3/8" (25, 30 HP)	837506-094	837506-094	2
14	nut, hex 3/8"-16 (25, 30HP)	824206-337	824206-337	2

(I) For maintenance on air filter no. 043333, order replacement element no. 043334.

(II) For maintenance on air filter no. 040595, order replacement element no. 040596.

PLEASE NOTE: WHEN ORDERING PARTS, INDICATE SERIAL NUMBER OF COMPRESSOR

Section 1
ILLUSTRATIONS AND PARTS LIST

1.17 OPTIONAL AIR TANK -- 120 AND 200 GALLON

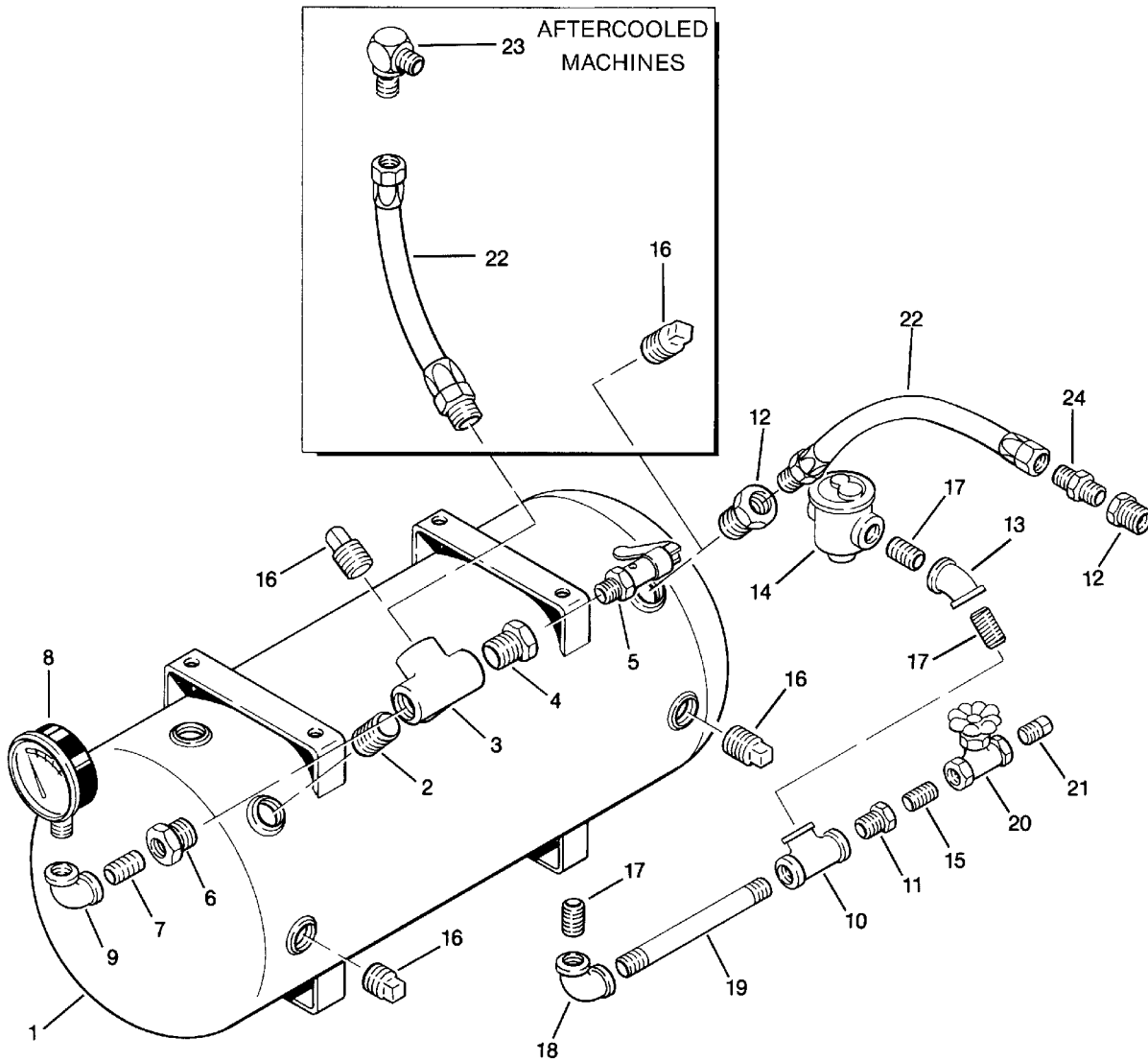

Section 1

ILLUSTRATIONS AND PARTS LIST

1.17 OPTIONAL AIR TANK -- 120 AND 200 GALLON

<i>key number</i>	<i>description</i>	<i>standard part number</i>	<i>24KT part number</i>	<i>quantity</i>
1	tank, receiver (120 gallon)	042878	042878	1
	tank, receiver (200 gallon)	042877	042877	1
2	nipple, pipe 1 1/4" x close	822220-000	822220-000	1
3	tee, side outlet 1 1/4"	802715-050	802715-050	1
4	bushing, hex 1 1/4" x 1/2"	802105-020	802105-020	1
5	valve, pressure relief	043041	043041	1
6	bushing, hex 1 1/4" x 1/4"	802105-010	802105-010	1
7	nipple, close 1/4"	823204-000	823204-000	1
8	gauge, pressure	040691	040691	1
9	elbow, pipe 1/4" 90°	803515-010	803515-010	1
10	tee, pipe 3/4"	802415-030	802415-030	1
11	bushing, hex 3/4" x 3/8"	802103-015	802103-015	1
12	bushing, hex 1 1/4" x 1"	802105-040	802105-040	2
13	elbow, pipe 3/4" 45°	801415-030	801415-030	1
14	trap, automatic 3/4"	042034	042034	1
15	nipple, close 3/8" xs	822206-000	822206-000	1
16	plug, pipe 1 1/4"	802815-050	802815-050	4
17	nipple, close 3/4"	822212-000	822212-000	3
18	elbow, pipe 3/4"	801515-030	801515-030	1
19	nipple, pipe 3/4" x 8"	822112-080	822112-080	1
20	valve, globe	042733	042733	1
21	plug, pipe 3/8"	807800-015	807800-015	1
(ALL NON-AFTER COOLED COMPRESSORS)				
22	hose, assembly 1" x 40" (25/30/40HP ac and wc)	248369	248369	1
23	elbow, 37° flare 90° m 3/4" x 1" (25/30HP ac)	860216-075	860216-075	1
	elbow, 37° flare 90° m 1" x 1" (25/30HP wc and 40HP ac)	860216-100	860216-100	1

PLEASE NOTE: WHEN ORDERING PARTS, INDICATE SERIAL NUMBER OF COMPRESSOR

Section 1 ILLUSTRATIONS AND PARTS LIST

1.18 DECAL GROUP

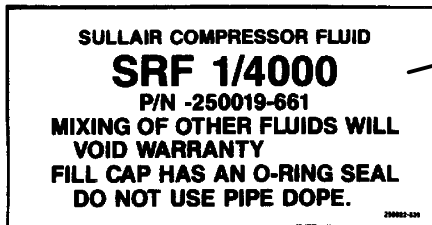
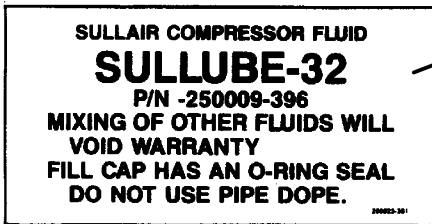
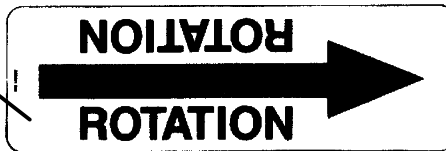
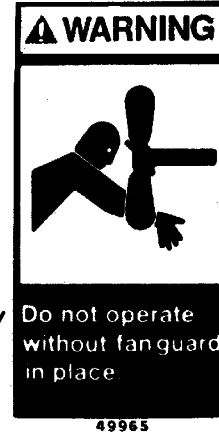
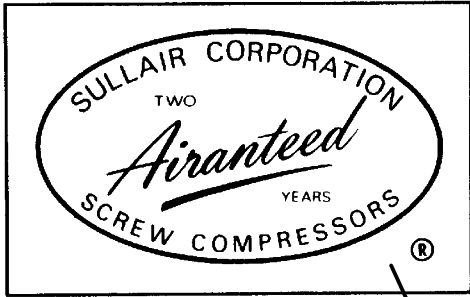

GENUINE SULLAIR SERVICE PARTS

MODEL: 10B-40HP

DESCRIPTION:	P/N
• ELEMENT, AIR FILTER STD.	042445
ELEMENT, FLUID FILTER (FG.)	250025-525
ELEMENT, SEPARATOR	250034-114
KIT, FLUID RETURN LINE	241772
KIT, AIR INLET VALVE	250019-451
KIT, THERMAL VALVE	250025-621

• • STD. COMPRESSOR FLUID OPTIONS:

SRF 1/4000 FLUID (5 GAL.)	250019-662
SULLUBE 32 FLUID (5 GAL.)	250025-659
24KT FLUID (5 GAL.)	046856-001

• • SEE COMP. FILL DECAL FOR CORRECT FLUID

• HEAVY DUTY FILTER OPTION

ELEMENT, AIR FILTER	040596
---------------------	--------

THE ABOVE PARTS MAY ALSO BE ORDERED AS AN ANNUAL MAINTENANCE KIT:

105 W/STD. AIR FILTER	250027-927
105 W/H.D. AIR FILTER	250027-931

THE ABOVE PARTS SHOULD BE ORDERED FROM A LOCAL SULLAIR DISTRIBUTOR. FOR INFORMATION REGARDING THE LOCATION OF YOUR NEAREST SULLAIR DISTRIBUTOR CONTACT:

SULLAIR CORPORATION TEL. (219) 874-1800
PARTS DIVISION 800 348-2722
1525 E. SECOND ST.
MICHIGAN CITY, IN. 46360

250034-136

Section 1
ILLUSTRATIONS AND PARTS LIST

1.18 DECAL GROUP

<i>key number</i>	<i>description</i>	<i>standard part number</i>	<i>24KT part number</i>	<i>quantity</i>
1	decal, airanteed 2 year – white	043067	043067	1
2	sign, warning sever fan	049855	049855	2
3	sign, warning sever fan port	049965	049965	1
4	sign, danger electrocution	049850	049850	1
5	decal, rotation	250021 – 286	250021 – 286	1
6	decal, 460 volt	040631	040631	1
7	decal, grounding lug	045433	045433	1
8	decal, compressor fluid Sullube–32	250023 – 361	250023 – 361	1
9	decal, SRF 1/4000 fluid	250022 – 839	250022 – 839	1
10	decal, 10–B–40HP maintenance kit	250034 – 136	250034 – 136	1

(Continued on Page 47)

PLEASE NOTE: WHEN ORDERING PARTS, INDICATE SERIAL NUMBER OF COMPRESSOR

Section 1
ILLUSTRATIONS AND PARTS LIST

1.18 DECAL GROUP

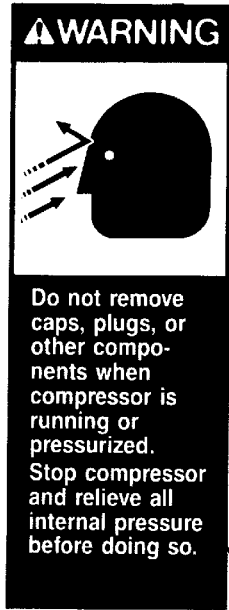

11



12

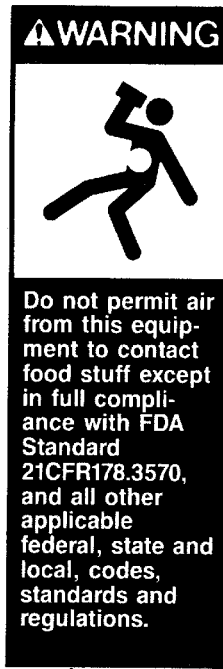

13

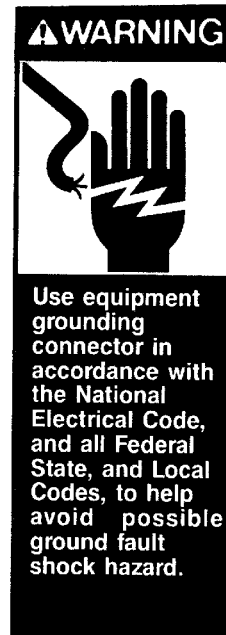

14

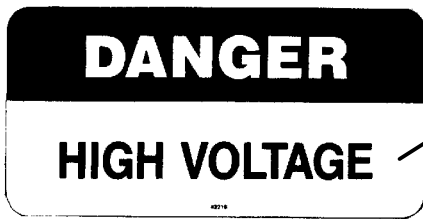

15



16

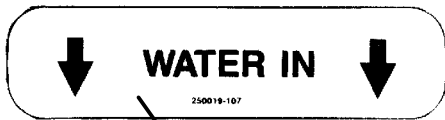

17

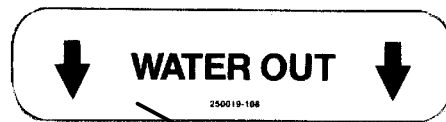

18

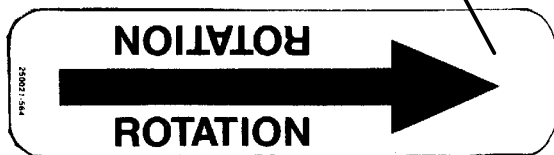

19

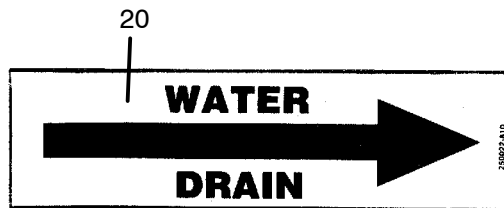

20

Section 1
ILLUSTRATIONS AND PARTS LIST

1.18 DECAL GROUP (Continued)

<i>key number</i>	<i>description</i>	<i>standard part number</i>	<i>24KT part number</i>	<i>quantity</i>
11	sign, warning compressor oil fill cap	049685	049685	1
12	sign, danger air breathing	250027-935	250027-935	1
13	sign, warning "food grade" lube	250003-144	250003-144	1
14	sign, warning ground fault	049852	049852	1
15	decal, danger high voltage	042218	042218	1
16	decal, water inlet/outlet	049873	049873	1
17	decal, water in	250019-107	250019-107	1
18	decal, water out	250019-108	250019-108	1
19	decal, rotation	250021-564	250021-564	1
20	decal, water drain	250022-810	250022-810	1
21	decal, Sullair 16 $\frac{3}{4}$ " - white (not shown)	250014-057	250014-057	1
22	decal, logo - white (not shown)	040087A	040087A	1

PLEASE NOTE: WHEN ORDERING PARTS, INDICATE SERIAL NUMBER OF COMPRESSOR

NOTES

NOTES

WORLDWIDE SALES AND SERVICE

SULLAIR CORPORATION

A SUBSIDIARY OF SUNDSTRAND CORPORATION

3700 E. Michigan Blvd. Michigan City, Indiana 46360-9990
Telephone (219) 879-5451



Printed in U.S.A.

Specifications Subject To
Change Without Prior Notice